

# Reed Switch and Solenoid Kits 24B771 and 24B772

Husky® 1050 Diaphragm Pumps

406825E

EN



### Important Safety Instructions

Read all warnings and instructions in the Husky® 1050 Air-Operated Diaphragm Pump Repair/Parts manual. Save all instructions.

### Kit 24B771

for pumps with a polypropylene or conductive polypropylene center section and air valve.

Ref.	Description	Qty.
101	REED SWITCH/SOLENOID ASSEMBLY	1
102	SCREW, reed switch, 10-14 x 1/2 plastite	1
103	BRACKET, solenoid	1
104	FASTENER, solenoid, M6 hex nut	2

### Kit 24B772

for pumps with an aluminum center section and air valve.

Ref.	Description	Qty.
101	REED SWITCH/SOLENOID ASSEMBLY	1
102	SCREW, reed switch, 8-32 x 1.50	1
103	BRACKET, solenoid	1
104	FASTENER, solenoid, M6 x 25 screw	2

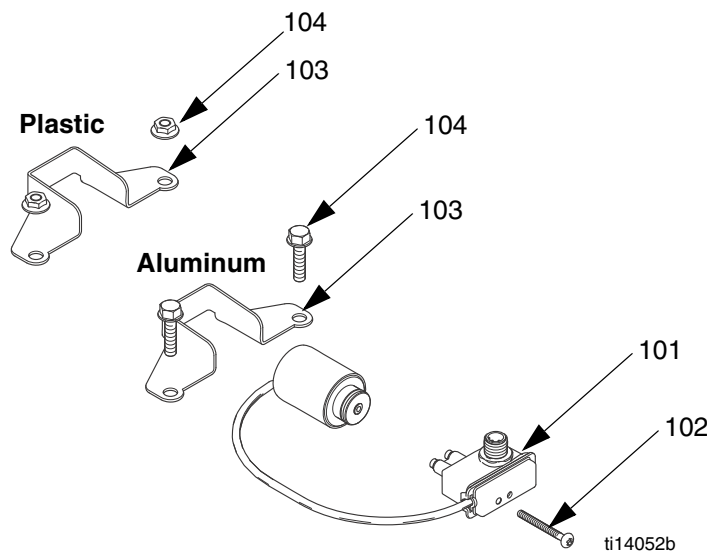

# Installation

**NOTE:** These kits are intended to replace a reed switch/solenoid assembly. Contact your distributor to order the correct conversion kit to add monitoring capabilities.

1. Attach the solenoid (S) and bracket (103) to the air valve. Use the same screws (104) that attach the air valve to the center housing, as shown.

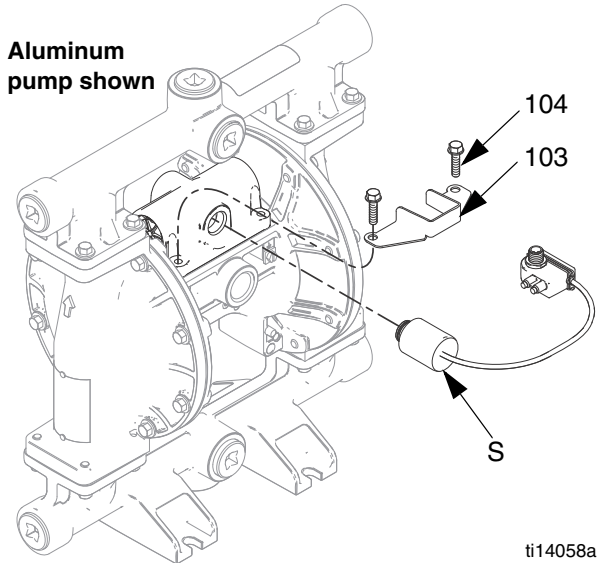

2. Use the screw provided to attach the reed switch just behind the air inlet. Remove the muffler, if needed, for easier access. Rotate the air inlet fitting as needed so the wrench flat clears the reed switch.

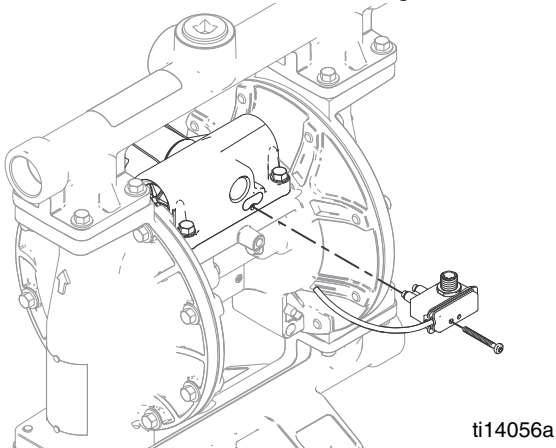

3. Connect the DataTrak cable to the 5-pin connector on the reed switch. Reconnect the air line to the motor.

*All written and visual data contained in this document reflects the latest product information available at the time of publication. Graco reserves the right to make changes at any time without notice.*

Original instructions. This manual contains English. MM 406825

For patent information, see [www.graco.com/patents](http://www.graco.com/patents).

**Graco Headquarters:** Minneapolis

**International Offices:** Belgium, China, Japan, Korea

**GRACO INC. AND SUBSIDIARIES • P.O. BOX 1441 • MINNEAPOLIS MN 55440-1441 • USA**

**Copyright 2009, Graco Inc. All Graco manufacturing locations are registered to ISO 9001.**

[www.graco.com](http://www.graco.com)  
Revised April 2013