

## Reactor<sup>®</sup> 3 Proportioning Systems

3A8501F

EN

***Electric, heated, plural component proportioner for spraying polyurethane foam and polyurea coatings. For indoor use only. Not approved for use in explosive atmospheres or hazardous (classified) locations. Only use with Reactor 3 heated hoses. For professional use only.***

See pages 4 and 5 for model information, including maximum working pressure and approvals.



### **Important Safety Instructions**

Read all warnings and instructions in this manual and in related manuals before using the equipment. Save these instructions.

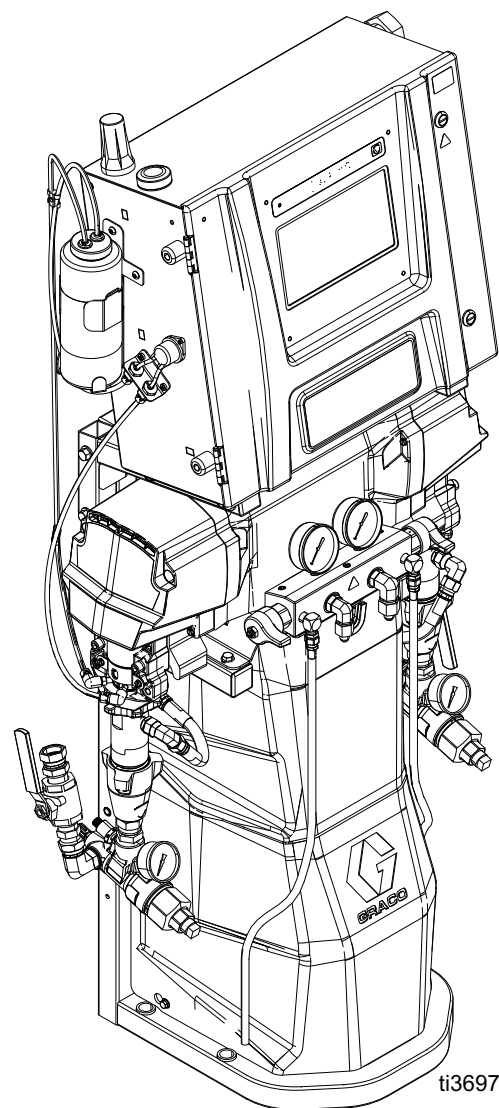

# Contents

<b>Supplied Manuals</b> .....	<b>3</b>	<b>Repair</b> .....	<b>22</b>
<b>Related Manuals</b> .....	<b>3</b>	Before Beginning Repair.....	22
<b>Models</b> .....	<b>4</b>	Flush Inlet Strainer Screen.....	22
Reactor E-20 and E-30.....	4	Change ISO Pump Throat Seal Lubricant	
Reactor E-XP1 and E-XP2.....	5	(TSL) Fluid.....	23
<b>Approvals</b> .....	<b>6</b>	Remove Pump.....	24
<b>Accessories</b> .....	<b>6</b>	Install Pump.....	26
<b>Warnings</b> .....	<b>7</b>	Motor Replacement.....	27
<b>Important Isocyanate Information</b> .....	<b>11</b>	Replace Circuit Breaker.....	30
Isocyanate Conditions.....	11	Replace Inlet Pressure Transducer.....	31
Material Self-Ignition.....	12	Replace Inlet Temperature Sensor.....	31
Keep Components A and B Separate.....	12	Replace Outlet Pressure Transducers.....	32
Changing Materials.....	12	Replace Fans.....	32
Moisture Sensitivity of Isocyanates.....	12	Replace Flow Meter.....	34
Foam Resins with 245 fa Blowing Agents.....	12	Repair Primary Heater.....	35
<b>Notes</b> .....	<b>13</b>	Replace Over-Temperature Switch.....	36
<b>Component Identification</b> .....	<b>14</b>	Replace RTD.....	37
Proportioner.....	14	Troubleshoot Heated Hose.....	38
Electrical Enclosure.....	16	Check Hose RTD Cables and FTS.....	38
Temperature Control Module (TCM).....	17	Repair Fluid Temperature Sensor (FTS).....	40
Motor Control Module (MCM).....	17	Calibration Procedure.....	41
Advanced Display Module (ADM).....	18	Transformer Check.....	41
<b>Pressure Relief Procedure</b> .....	<b>19</b>	Replace Transformer.....	42
<b>Shutdown</b> .....	<b>20</b>	Replace Power Supply.....	43
<b>Flush the Equipment</b> .....	<b>21</b>	Replace Surge Protector.....	43
		Replace Motor Control Module (MCM).....	44
		Replace Temperature Control Module (TCM).....	44
		Replace Advanced Display Module (ADM).....	45
		Software Update Procedure.....	45
		Software Update Procedure USB.....	46
		Over-the-Air Software Updates.....	47
		Replace Fluid Outlet Manifold.....	48
		<b>Parts</b> .....	<b>49</b>
		Top Level Units.....	49
		Drivers Parts.....	54
		Heaters.....	56
		Manifolds.....	58
		Electrical Enclosures Parts.....	60
		Inlet Strainers Parts.....	62
		Rail Module Parts.....	64
		Ship Loose Parts.....	67
		Repair Kits.....	68
		<b>Electrical Schematics</b> .....	<b>69</b>
		<b>Recycling and Disposal</b> .....	<b>76</b>
		End of Product Life.....	76
		<b>California Proposition 65</b> .....	<b>76</b>
		<b>Technical Specifications</b> .....	<b>77</b>
		Reactor E-20.....	77
		Reactor E-XP1.....	78
		Reactor E-30.....	79
		Reactor E-XP2.....	80
		<b>Graco Extended Warranty for</b>	
		<b>Reactor® Components</b> .....	<b>81</b>

# Supplied Manuals

Manual in English	Description
3A8500	Reactor 3 Proportioner Operation
3A8501	Reactor 3 Proportioner Repair
3A8505	Reactor 3 Startup Quick Guide
3A8506	Reactor 3 Shutdown Quick Guide

# Related Manuals

The following manuals are for accessories used with the Reactor Proportioner.

Manuals are available at [www.graco.com](http://www.graco.com).

Manual in English	Description
<b>Feed System Manuals</b>	
309852	Circulation and Return Hose Kit, Instructions-Parts
3A8502	T4 3:1 Ratio Transfer Pump, Operation and Parts
3A8503	E1 Transfer Pumps, Operation and Parts
<b>Displacement Pump Manual</b>	
309577	Electric Reactor Displacement Pump, Repair-Parts
<b>Spray Gun Manuals</b>	
309550	Fusion® AP Spray Gun, Instructions
3A7314	Fusion PC Spray Gun, Instructions
312666	Fusion CS Spray Gun, Instructions
309856	Fusion MP Spray Gun, Instructions-Parts
313213	Probler® P2 Gun, Instructions
<b>Reactor Connect Manual</b>	
3A8504	Reactor Connect, Instructions
<b>Heated Hose Manual</b>	
3A7683	Reactor Heated Hose (Reactor 3), Instructions

# Models

## Reactor E-20 and E-30

	Model (Part Number)	E-20 Standard 7 kW (26R310)	E-20 Pro 7 kW (26R311)	E-20 Pro 10 kW (26R313)	E-20 Elite 10 kW (26R312)	E-30 Standard 10 kW (26R330)	E-30 Pro 10 kW (26R331)	E-30 Pro 15 kW (26R333)	E-30 Elite 15 kW (26R332)
<b>Technical Information</b>	Maximum working pressure	2000 psi (14 MPa, 140 bar)	2000 psi (14 MPa, 140 bar)	2000 psi (14 MPa, 140 bar)	2000 psi (14 MPa, 140 bar)	2000 psi (14 MPa, 140 bar)	2000 psi (14 MPa, 140 bar)	2000 psi (14 MPa, 140 bar)	2000 psi (14 MPa, 140 bar)
	Approximate output / cycle A + B	0.0104 gal (0.0395 L)	0.0104 gal (0.0395 L)	0.0104 gal (0.0395 L)	0.0104 gal (0.0395 L)	0.0273 gal (0.103 L)	0.0273 gal (0.103 L)	0.0273 gal (0.103 L)	0.0273 gal (0.103 L)
	Maximum flow	20 lb/min (9.1 kg/min)	20 lb/min (9.1 kg/min)	20 lb/min (9.1 kg/min)	20 lb/min (9.1 kg/min)	30 lb/min (13.5 kg/min)	30 lb/min (13.5 kg/min)	30 lb/min (13.5 kg/min)	30 lb/min (13.5 kg/min)
	Max heated hose length supported	220 ft (67 m)	220 ft (67 m)	220 ft (67 m)	220 ft (67 m)	320 ft (97.5 m)	320 ft (97.5 m)	320 ft (97.5 m)	320 ft (97.5 m)
	Total system load	12.9 kW	12.9 kW	15 kW	15 kW	17.5 kW	17.5 kW	22.3 kW	22.3 kW
	Primary heater load	7.6 kW	7.6 kW	9.6 kW	9.6 kW	9.6 kW	9.6 kW	14.4 kW	14.4 kW
	Full load peak current	200-240 VAC 1 phase	56 A	56 A	65 A	65 A	76 A	76 A	97 A
	200-240 VAC 3 phase delta	36 A	36 A	39 A	39 A	49 A	49 A	59 A	
	350-415 VAC 3 phase Y	24 A	24 A	24 A	24 A	35 A	35 A	35 A	
<b>System Features</b>	Ratio monitoring				✓				✓
	Reactor Connect app		✓	✓	✓		✓	✓	✓
	Large-ported recirculation valves		✓	✓	✓		✓	✓	✓
	Software includes auto-pressure balancing and power management		✓	✓	✓		✓	✓	✓
	Tank-level dip sticks		✓	✓	✓		✓	✓	✓
	Large inlet strainer with gauge, pressure, and temperature sensors				✓				✓
	Large inlet strainer with gauge		✓	✓			✓	✓	
	Small inlet strainer with no gauge	✓					✓		
<b>Packages</b>	Externally heated hose package, 1 x 50 ft (15.24 m)	ESR310★	ESR311★	ESR313★	ESR312◆●	ESR330★	ESR331★	ESR333★	ESR332◆●
	Externally heated hose package, 2 x 100 ft (30.48 m)	EHR310★	EHR311★	EHR313★	EHR312◆●	EHR330★	EHR331★	EHR333★	EHR332◆●
	Internally heated hose package, 1 x 50 ft (15.24 m)	ISR310★	ISR311★	ISR313★	ISR312◆●	ISR330★	ISR331★	ISR333★	ISR332◆●
	Internally heated hose package, 2 x 100 ft (30.48 m)	IHR310★	IHR311★	IHR313★	IHR312◆●	IHR330★	IHR331★	IHR333★	IHR332◆●
	Core E1 with internally heated hose package, 1 x 50 ft (15.24 m)				CSR312◆●				CSR332◆●
	Core E1 with internally heated package, 2 x 100 ft (30.48 m)				CHR312◆●				CHR332◆●

◆ Includes engine CAN diagnostic cable.

● Includes 20 ft (6.1 m) whip hose.

★ Includes 10 ft (3.05 m) whip hose.



## Reactor E-XP1 and E-XP2

	Model (Part Number)	E-XP1 Standard 10 kW (26R320)	E-XP1 Pro 10 kW (26R321)	E-XP1 Elite 10 kW (26R322)	E-XP2 Standard 15 kW (26R340)	E-XP2 Pro 15 kW (26R341)	E-XP2 Elite (15 kW (26R342)
<b>Technical Information</b>	Maximum working pressure	3000 psi (20.7 MPa, 207 bar)	3000 psi (20.7 MPa, 207 bar)	3000 psi (20.7 MPa, 207 bar)	3500 psi (24.1 MPa, 241 bar)	3500 psi (24.1 MPa, 241 bar)	3500 psi (24.1 MPa, 241 bar)
	Approximate output / cycle A + B	0.0104 gal (0.0395 L)	0.0104 gal (0.0395 L)	0.0104 gal (0.0395 L)	0.0204 gal (0.0771 L)	0.0204 gal (0.0771 L)	0.0204 gal (0.0771 L)
	Maximum flow	2 gpm (7.6 lpm)	2 gpm (7.6 lpm)	2 gpm (7.6 lpm)	2.1 gpm (7.9 lpm)	2.1 gpm (7.9 lpm)	2.1 gpm (7.9 lpm)
	Maximum heated hose length supported	220 ft (67 m)	220 ft (67 m)	220 ft (67 m)	320 ft (97.5 m)	320 ft (97.5 m)	320 ft (97.5 m)
	Total system load	15 kW	15 kW	15 kW	22.3 kW	22.3 kW	22.3 kW
	Primary heater load	9.6 kW	9.6 kW	9.6 kW	14.4 kW	14.4 kW	14.4 kW
	Full load peak current	200-240 VAC 1 phase	65 A	65 A	65 A	97 A	97 A
200-240 VAC 3 phase delta		39 A	39 A	39 A	59 A	59 A	59 A
350-415 VAC 3 phase Y		24 A	24 A	24 A	35 A	35 A	35 A
<b>System Features</b>	Ratio monitoring			✓			✓
	Reactor Connect app		✓	✓		✓	✓
	Large-ported recirculation valves		✓	✓		✓	✓
	Software includes auto-pressure balancing and power management		✓	✓		✓	✓
	Tank-level dip sticks		✓	✓		✓	✓
	Large inlet strainer with gauge, pressure, and temperature sensors			✓			✓
	Large inlet strainer with gauge		✓			✓	
	Small inlet strainer with no gauge	✓			✓		
<b>Packages</b>	Externally heated hose package, 1 x 50 ft (15.24 m)	ESR320★	ESR321★	ESR322◆•	ESR340★	ESR341★	ESR342◆•
	Externally heated hose package, 2 x 100 ft (30.48 m)	EHR320★	EHR321★	EHR322◆•	EHR340★	EHR341★	EHR342◆•
	Internally heated hose package, 1 x 50 ft (15.24 m)	ISR320★	ISR321★	ISR322◆•	ISR340★	ISR341★	ISR342◆•
	Internally heated hose package, 2 x 100 ft (30.48 m)	IHR320★	IHR321★	IHR322◆•	IHR340★	IHR341★	IHR342◆•
	Core E1 with internally heated hose package, 1 x 50 ft (15.24 m)			CSR322◆•			CSR342◆•
	Core E1 with internally heated hose package, 2 x 100 ft (30.48 m)			CHR322◆•			CHR342◆•

◆ Includes engine CAN diagnostic cable.

• Includes 20 ft (6.1 m) whip hose.

★ Includes 10 ft (3.05 m) whip hose.

# Approvals

Intertek approvals apply to proportioners without hoses.

**Proportioner Approvals:**



**Intertek**  
9902471  
Conforms to ANSI/UL Std. 499  
Certified to CAN/CSA Std. C22.2 No.88

CE

UK

CA



EAC



# Accessories

Kit Number	Description
20A677	Engine CAN Kit
24M174	Drum Level Sticks
20A676	Light Tower Kit
18E191	Off-Ratio Kits
18E192	
18E154	Air Manifold Kit
18E211	Cellular Mobile Remote Mounting Kit









# Warnings

The following warnings are for the setup, use, grounding, maintenance, and repair of this equipment. The exclamation point symbol alerts you to a general warning and the hazard symbols refer to procedure-specific risks. When these symbols appear in the body of this manual or on warning labels, refer back to these Warnings. Product-specific hazard symbols and warnings not covered in this section may appear throughout the body of this manual where applicable.

 <b>DANGER</b>	
 	<p><b>SEVERE ELECTRIC SHOCK HAZARD</b></p> <p>This equipment can be powered by more than 240 V. Contact with this voltage will cause death or serious injury.</p> <ul style="list-style-type: none"> <li>• Turn off and disconnect power at main switch before disconnecting any cables and before servicing or installing equipment.</li> <li>• This equipment must be grounded. Connect only to grounded power source.</li> <li>• All electrical wiring must be done by a qualified electrician and comply with all local codes and regulations.</li> </ul>

 <b>WARNING</b>	
	<p><b>TOXIC FLUID OR FUMES HAZARD</b></p> <p>Toxic fluids or fumes can cause serious injury or death if splashed in the eyes or on skin, inhaled or swallowed.</p> <ul style="list-style-type: none"> <li>• Read Safety Data Sheets (SDSs) for handling instructions and to know the specific hazards of the fluids you are using, including the effects of long-term exposure.</li> <li>• When spraying, servicing equipment, or when in the work area, always keep work area well-ventilated and always wear appropriate personal protective equipment. See <b>Personal Protective Equipment</b> warnings in this manual.</li> <li>• Store hazardous fluid in approved containers, and dispose of it according to applicable guidelines.</li> </ul>
	<p><b>PERSONAL PROTECTIVE EQUIPMENT</b></p> <p>Always wear appropriate personal protective equipment and cover all skin when spraying, servicing equipment, or when in the work area. Protective equipment helps prevent serious injury, including long-term exposure; inhalation of toxic fumes, mists or vapors; allergic reaction; burns; eye injury and hearing loss. This protective equipment includes but is not limited to:</p> <ul style="list-style-type: none"> <li>• A properly fitting respirator, which may include a supplied-air respirator, chemically impermeable gloves, protective clothing and foot coverings as recommended by the fluid manufacturer and local regulatory authority.</li> <li>• Protective eyewear and hearing protection.</li> </ul>

# **WARNING**

    	<p><b>SKIN INJECTION HAZARD</b></p> <p>High-pressure fluid from gun, hose leaks, or ruptured components will pierce skin. This may look like just a cut, but it is a serious injury that can result in amputation. <b>Get immediate surgical treatment.</b></p> <ul style="list-style-type: none"> <li>• Do not spray without tip guard and trigger guard installed.</li> <li>• Engage trigger lock when not spraying.</li> <li>• Do not point gun at anyone or at any part of the body.</li> <li>• Do not put your hand over the spray tip.</li> <li>• Do not stop or deflect leaks with your hand, body, glove, or rag.</li> <li>• Follow the <b>Pressure Relief Procedure</b> when you stop spraying and before cleaning, checking, or servicing equipment.</li> <li>• Tighten all fluid connections before operating the equipment.</li> <li>• Check hoses and couplings daily. Replace worn or damaged parts immediately.</li> </ul>
   	<p><b>FIRE AND EXPLOSION HAZARD</b></p> <p>Flammable fumes, such as solvent and paint fumes, in <b>work area</b> can ignite or explode. Paint or solvent flowing through the equipment can cause static sparking. To help prevent fire and explosion:</p> <ul style="list-style-type: none"> <li>• Use equipment only in well-ventilated area.</li> <li>• Eliminate all ignition sources, such as pilot lights, cigarettes, portable electric lamps, and plastic drop cloths (potential static sparking).</li> <li>• Ground all equipment in the work area. See <b>Grounding</b> instructions.</li> <li>• Never spray or flush solvent at high pressure.</li> <li>• Keep work area free of debris, including solvent, rags and gasoline.</li> <li>• Do not plug or unplug power cords, or turn power or light switches on or off when flammable fumes are present.</li> <li>• Use only grounded hoses.</li> <li>• Hold gun firmly to side of grounded pail when triggering into pail. Do not use pail liners unless they are anti-static or conductive.</li> <li>• <b>Stop operation immediately</b> if static sparking occurs or you feel a shock. Do not use equipment until you identify and correct the problem.</li> <li>• Keep a working fire extinguisher in the work area.</li> </ul>

# WARNING



## THERMAL EXPANSION HAZARD

Fluids subjected to heat in confined spaces, including hoses, can create a rapid rise in pressure due to the thermal expansion. Over-pressurization can result in equipment rupture and serious injury.

- Open a valve to relieve the fluid expansion during heating.
- Replace hoses proactively at regular intervals based on your operating conditions.



## PRESSURIZED ALUMINUM PARTS HAZARD

Use of fluids that are incompatible with aluminum in pressurized equipment can cause serious chemical reaction and equipment rupture. Failure to follow this warning can result in death, serious injury, or property damage.

- Do not use 1,1,1-trichloroethane, methylene chloride, other halogenated hydrocarbon solvents or fluids containing such solvents.
- Do not use chlorine bleach.
- Many other fluids may contain chemicals that can react with aluminum. Contact your material supplier for compatibility.



## EQUIPMENT MISUSE HAZARD

Misuse can cause death or serious injury.

- Do not operate the unit when fatigued or under the influence of drugs or alcohol.
- Do not exceed the maximum working pressure or temperature rating of the lowest rated system component. See **Technical Specifications** in all equipment manuals.
- Use fluids and solvents that are compatible with equipment wetted parts. See **Technical Specifications** in all equipment manuals. Read fluid and solvent manufacturer's warnings. For complete information about your material, request Safety Data Sheets (SDSs) from distributor or retailer.
- Do not leave the work area while equipment is energized or under pressure.
- Turn off all equipment and follow the **Pressure Relief Procedure** when equipment is not in use.
- Check equipment daily. Repair or replace worn or damaged parts immediately with genuine manufacturer's replacement parts only.
- Do not alter or modify equipment. Alterations or modifications may void agency approvals and create safety hazards.
- Make sure all equipment is rated and approved for the environment in which you are using it.
- Use equipment only for its intended purpose. Call your distributor for information.
- Route hoses and cables away from traffic areas, sharp edges, moving parts, and hot surfaces.
- Do not kink or over bend hoses or use hoses to pull equipment.
- Keep children and animals away from work area.
- Comply with all applicable safety regulations.



# **WARNING**



## **MOVING PARTS HAZARD**

Moving parts can pinch, cut or amputate fingers and other body parts.



- Keep clear of moving parts.
- Do not operate equipment with protective guards or covers removed.
- Equipment can start without warning. Before checking, moving, or servicing equipment, follow the **Pressure Relief Procedure** and disconnect all power sources.



## **BURN HAZARD**

Equipment surfaces and fluid that is heated can become very hot during operation. To avoid severe burns:

- Do not touch hot fluid or equipment.

# Important Isocyanate Information

Isocyanate (ISO) are catalysts used in two component materials.

## Isocyanate Conditions





Spraying or dispensing fluids that contain isocyanates creates potentially harmful mists, vapors, and atomized particulates.



- Read and understand the fluid manufacturer’s warnings and Safety Data Sheets (SDSs) to know specific hazards and precautions related to isocyanates.
- Use of isocyanates involves potentially hazardous procedures. Do not spray with this equipment unless you are trained, qualified, and have read and understood the information in this manual and in the fluid manufacturer’s application instructions and SDSs.
- Use of incorrectly maintained or mis-adjusted equipment may result in improperly cured material, which could cause off gassing and offensive odors. Equipment must be carefully maintained and adjusted according to instructions in the manual.
- To prevent inhalation of isocyanate mists, vapors and atomized particulates, everyone in the work area must wear appropriate respiratory protection. Always wear a properly fitting respirator, which may include a supplied-air respirator. Ventilate the work area according to instructions in the fluid manufacturer’s SDSs.
- Avoid all skin contact with isocyanates. Everyone in the work area must wear chemically impermeable gloves, protective clothing and foot coverings as recommended by the fluid manufacturer and local regulatory authority. Follow all fluid manufacturer recommendations, including those regarding handling of contaminated clothing. After spraying, wash hands and face before eating or drinking.
- Hazard from exposure to isocyanates continues after spraying. Anyone without appropriate personal protective equipment must stay out of the work area during application and after application for the time period specified by the fluid manufacturer. Generally this time period is at least 24 hours.
- Warn others who may enter work area of hazard from exposure to isocyanates. Follow the recommendations of the fluid manufacturer and local regulatory authority. Posting a placard such as the following outside the work area is recommended:



## Material Self-Ignition

				
Some materials may become self-igniting if applied too thick. Read material manufacturer's warnings and Safety Data Sheets (SDSs).				

## Keep Components A and B Separate

				
Cross-contamination can result in cured material in fluid lines which could cause serious injury or damage equipment. To prevent cross-contamination:				
<ul style="list-style-type: none"> <li>• <b>Never</b> interchange component A and component B wetted parts.</li> <li>• Never use solvent on one side if it has been contaminated from the other side.</li> </ul>				

## Changing Materials

NOTICE				
Changing the material types used in your equipment requires special attention to avoid equipment damage and downtime.				
<ul style="list-style-type: none"> <li>• When changing materials, flush the equipment multiple times to ensure it is thoroughly clean.</li> <li>• Always clean the fluid inlet strainers after flushing.</li> <li>• Check with your material manufacturer for chemical compatibility.</li> <li>• When changing between epoxies and urethanes or polyureas, disassemble and clean all fluid components and change hoses. Epoxies often have amines on the B (hardener) side. Polyureas often have amines on the B (resin) side.</li> </ul>				

## Moisture Sensitivity of Isocyanates

Exposure to moisture (such as humidity) will cause ISO to partially cure, forming small, hard, abrasive crystal that become suspended in the fluid. Eventually a film will form on the surface and the ISO will begin to gel, increasing in viscosity.

NOTICE				
Partially cured ISO will reduce performance and the life of all wetted parts.				
<ul style="list-style-type: none"> <li>• Always use a sealed container with a desiccant dryer in the vent, or a nitrogen atmosphere. <b>Never</b> store ISO in an open container.</li> <li>• Keep the ISO pump wet cup or reservoir (if installed) filled with appropriate TSL fluid. The TSL fluid creates a barrier between the ISO and the atmosphere.</li> <li>• Use only moisture-proof hoses compatible with ISO.</li> <li>• Never use reclaimed solvents, which may contain moisture. Always keep solvent containers closed when not in use.</li> <li>• Always lubricate threaded parts with an appropriate lubricant when reassembling.</li> <li>• Cycle material through the Reactor at least once per week when wetted and sitting idle. Use the A-side transfer pump to flush material through the A-side outlet manifold recirculation fitting. See <b>Flush the Equipment</b> on page 21.</li> <li>• The Reactor should not be stored after ingesting air or running out of material. Prior to storage, follow the Purge Air procedure in your operation manual.</li> </ul>				

**NOTE:** The amount of film formation and rate of crystallization varies depending on the blend of ISO, the humidity, and the temperature.

## Foam Resins with 245 fa Blowing Agents

Some foam blowing agents will froth at temperatures above 90 °F (33 °C) when not under pressure, especially if agitated. To reduce frothing, minimize preheating in a circulation system.





# Component Identification

## Proportioner

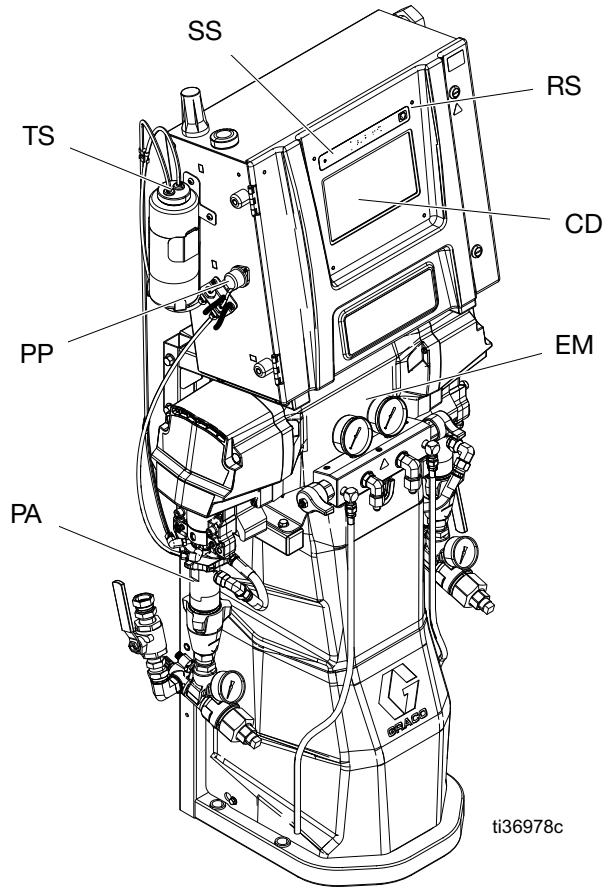
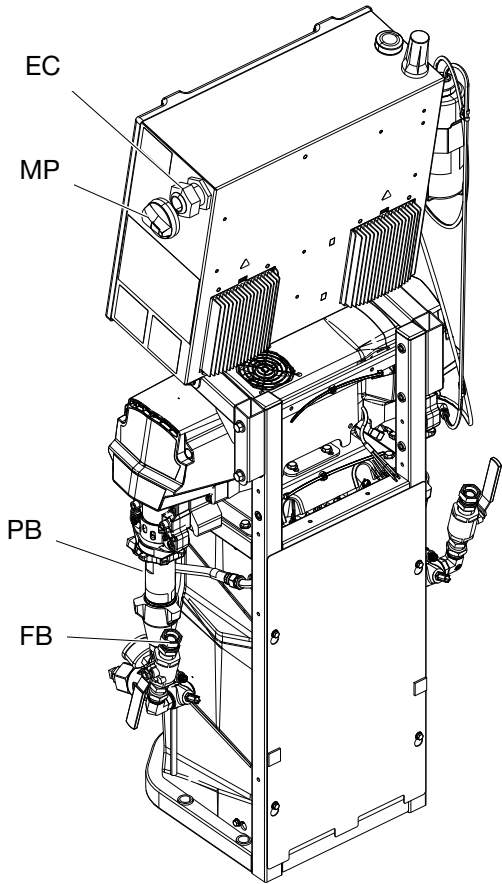

ti36978c

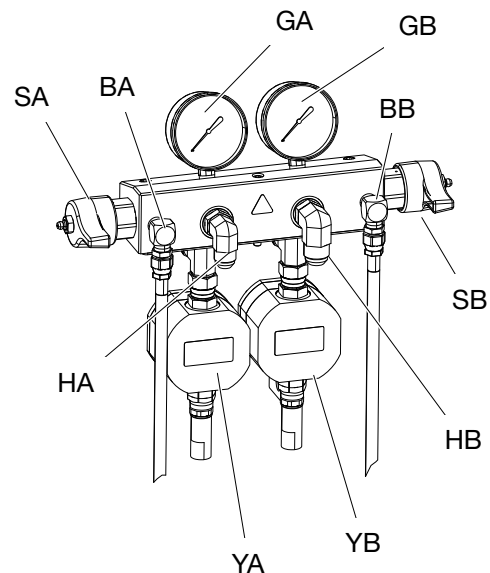
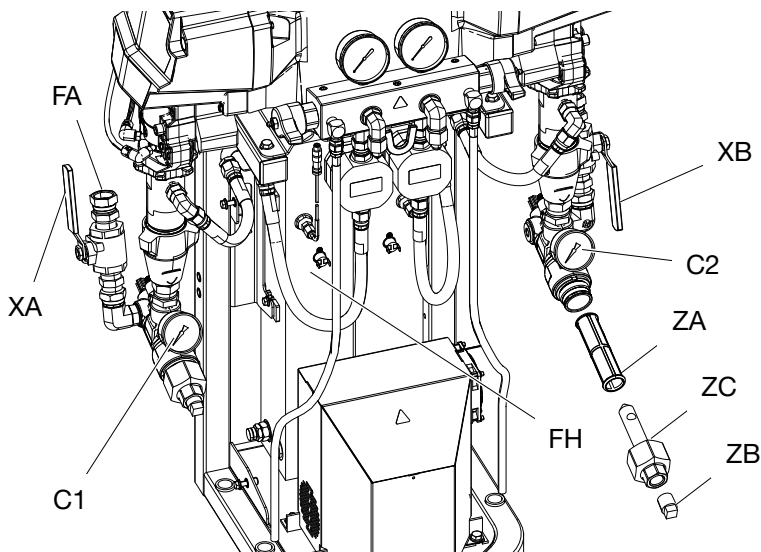

**Key**

<b>Ref.</b>	<b>Description</b>
BA	ISO Side Pressure Relief Outlet
BB	RES Side Pressure Relief Outlet
C1	ISO Side Inlet Pressure Gauge
C2	RES Side Inlet Pressure Gauge
CD	Advanced Display Module (ADM)
EC	Electrical Cord Strain Relief
EM	Electric Motor
FA	ISO Side Inlet Fitting
FB	RES Side Inlet Fitting
FH	Fluid Heaters
GA	ISO Side Pressure Gauge
GB	RES Side Pressure Gauge
HA	ISO Side Hose Connection
HB	RES Side Hose Connection
MP	Main Power Switch
PA	ISO Side Pump
PB	RES Side Pump
PP	ISO Lubrication Pump
RS	Red Stop Button
SA	ISO Side Pressure Relief/Spray Valve
SB	RES Side Pressure Relief/Spray Valve
TS	ISO Lubrication Reservoir
XA	ISO Side Fluid Inlet Valve
XB	RES Side Fluid Inlet Valve
YA	Flow Meter (ISO side, Elite models only)
YB	Flow Meter (RES side, Elite models only)
ZA	ZA Inlet Strainer Screen
ZB	Inlet Strainer Drain Plug
ZC	Inlet Strainer Cap

# Electrical Enclosure

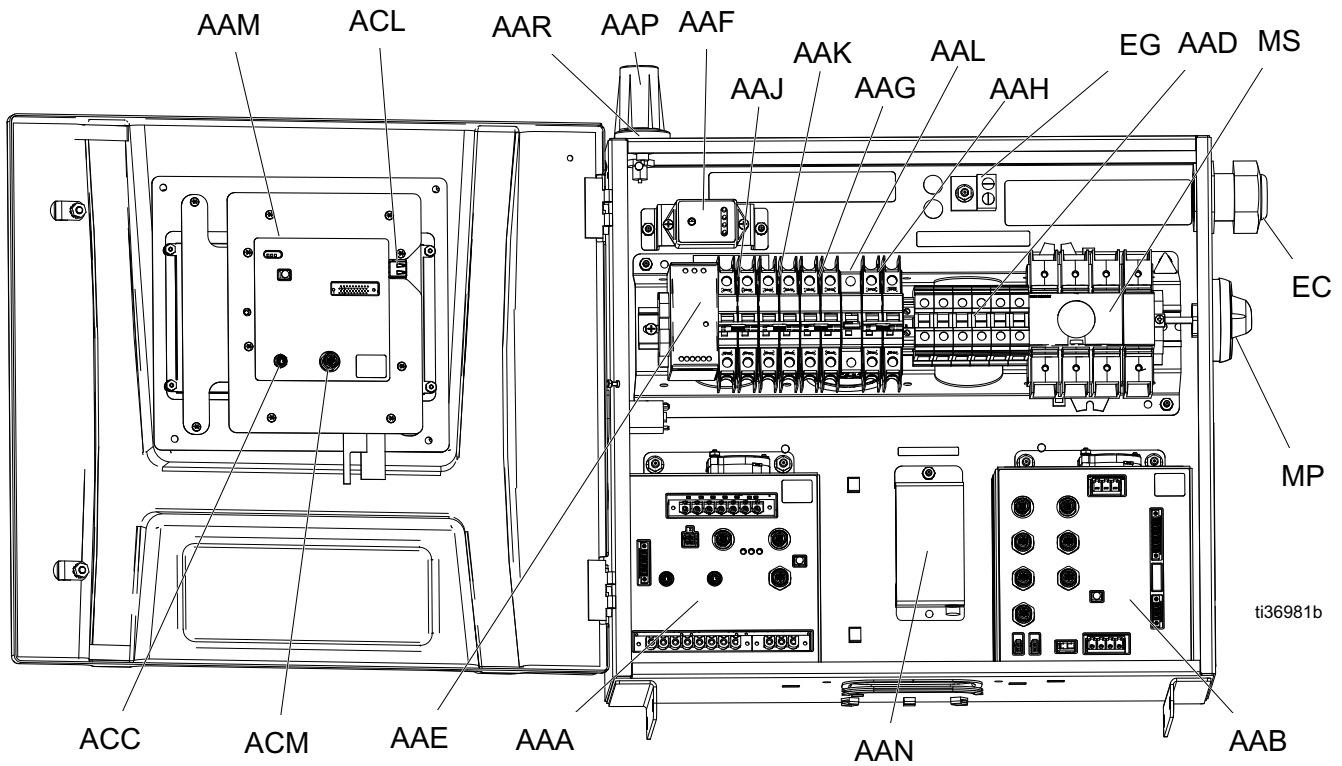

## Key

Ref.	Description
AAA	Temperature Control Module (TCM)
AAB	Motor Control Module (MCM)
AAD	Wiring Terminal Blocks
AAE	24V Power Supply
AAF	Surge Protector
AAG	Transformer Breaker
AAH	Motor Breaker
AAJ	A-Side Heat Breaker
AAK	B-Side Heat Breaker
AAL	Hose Breaker
AAM	Advance Display Module (ADM)

Ref.	Description
AAN†	Reactor Connect App Module
AAP†	Cellular Antenna
AAR†	GPS Antenna
ACC	Reactor Connect Module Cable Connection
ACL	ADM USB Port
ACM	ADM CAN Cable Connection
EC	Electrical Cord Strain Relief
EG	Incoming Power Ground Terminal
MP	Main Power Disconnect Knob
MS	Main Power Disconnect Switch

† Not included on all modules.

## Temperature Control Module (TCM)

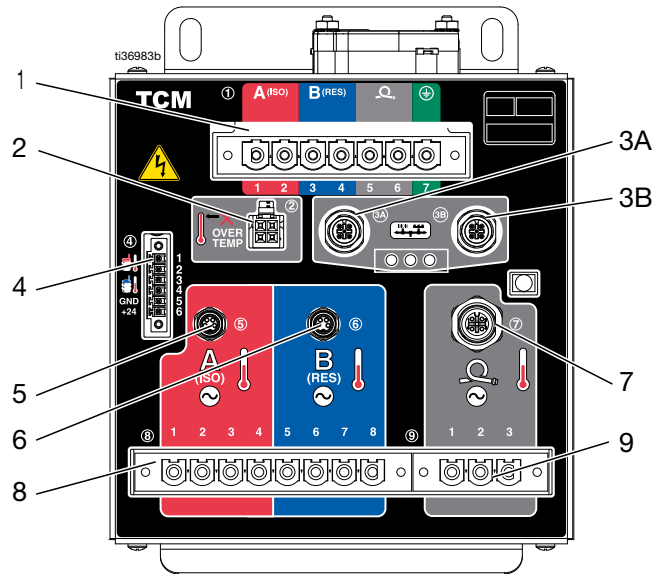

### Key

Ref.	Description
1	Main Power Input
2	Heater Over-Temperature Inputs
3A	CAN Communication Connections
3B	
4	A/B Inlet Temperatures and 24 VDC Power Supply Input
5	A Heater Temperature Input
6	B Heater Temperature Input
7	A/B Hose Temperature Inputs
8	A/B Heater Power Outputs
9	A/B Hose Power Outputs

## Motor Control Module (MCM)

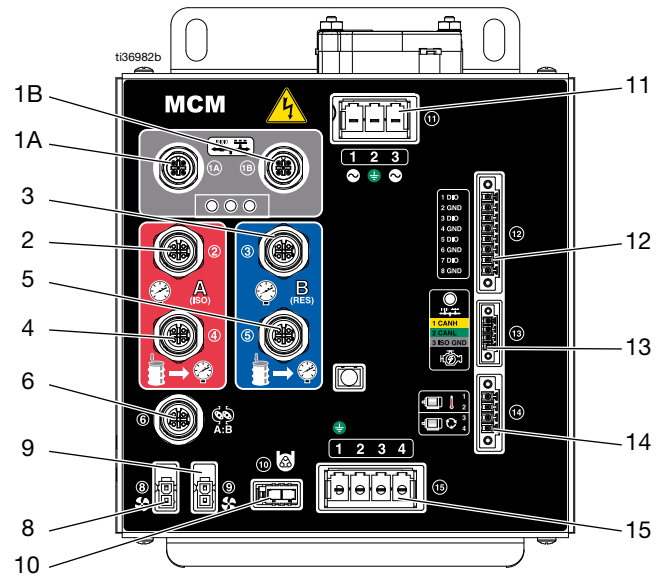

### Key

Ref.	Description
1A	CAN Communication Connections
1B	
2	A-side Pump Outlet Pressure
3	B-side Pump Outlet Pressure
4	A-side Pump Inlet Pressure
5	B-side Pump Inlet Pressure
6	Flow Meter Inputs
8	Transformer Fan
9	Motor Fan
10	ISO Lube Pump Output
11	Main Power Input
12	Digital Inputs/Outputs
13	Engine J1939 CAN Connection
14	Motor Temperature and Cycle Switch
15	Motor Output

## Advanced Display Module (ADM)

The ADM display shows graphical and text information related to setup and spray operations.

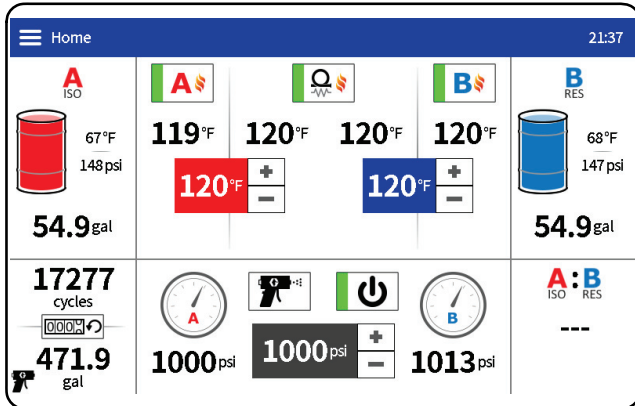

ti40087a

## ADM Keys and Indicators



Press to stop all proportioner processes.  
This is not a safety or emergency stop.

**NOTE:** For complete description of the ADM icons and screens, refer to your Reactor 3 operation manual.

# Pressure Relief Procedure



Follow the Pressure Relief Procedure whenever you see this symbol.

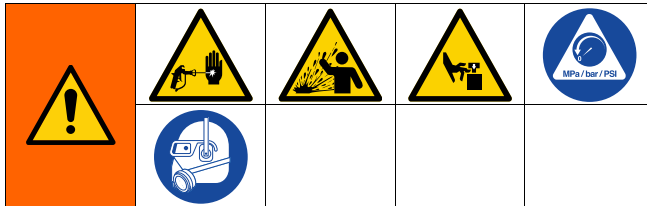

This equipment stays pressurized until pressure is manually relieved. To help prevent serious injury from pressurized fluid, such as skin injection, splashing fluid and moving parts, follow the Pressure Relief Procedure when you stop spraying and before cleaning, checking, or servicing the equipment.

1. Tap  to turn off the motor.

**NOTE:** Electric transfer pumps will automatically turn off with the motor.

2. Tap , , and  to turn off all heat zones.

3. Relieve pressure in the gun and perform the gun shutdown procedure. Refer to your gun manual (see **Related Manuals** on page 3).

4. Engage the gun piston safety lock.

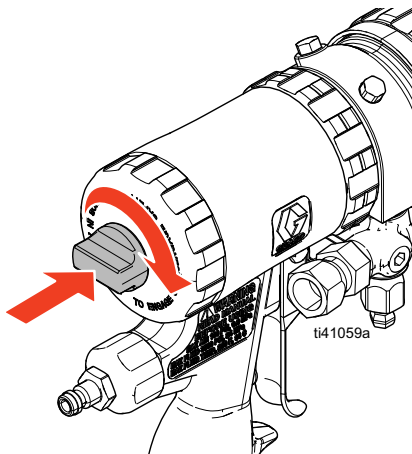

The Fusion AP gun is shown.

5. Close the gun fluid manifold valves A and B.

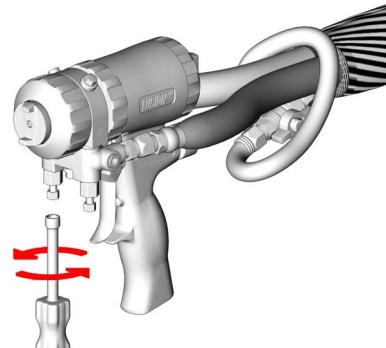

The Fusion AP gun is shown.

6. Shut off the transfer pumps and agitator, if used.

**For pneumatic transfer pumps and agitators:** refer to your component manuals (see **Related Manuals** on page 3).

For electric transfer pumps (if necessary), tap



to turn off A-side transfer pump power, and



to turn off B-side transfer pump power.

7. Make sure the bleed or circulation lines are connected and routed to waste containers or supply tanks. Turn the pressure relief/spray valves



(SA, SB) to pressure relief/circulation. Make sure the gauges drop to 0.

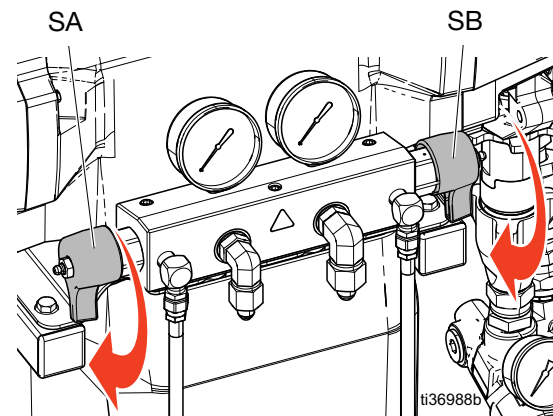

# Shutdown

**NOTICE**  
 Proper system setup, startup, and shutdown procedures are critical to electrical equipment reliability. The following procedures ensure steady voltage. Failure to follow these procedures will cause voltage fluctuations that can damage electrical equipment and void the warranty.

1. If using pneumatic transfer pumps, turn off air pressure to the transfer pumps. Refer to your pump manual, (see **Related Manuals** on page 3).

2. Tap  to turn off the motor.

**NOTE:** Electric transfer pumps will automatically turn off with the motor.

3. Tap , , and  to turn off all heat zones.

4. Follow the **Pressure Relief Procedure** on page 19).

5. Tap the pump mode button .

6. Select the Park mode icon from the drop down menu.

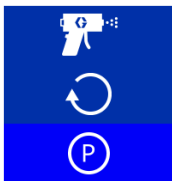

The park icon will flash red while the park operation is in progress. The park operation is complete when the motor and transfer pumps are off, and a green check appears next to the Park pump mode icon

7. . Verify the park operation is complete before moving to the next step.

**NOTE:** Pressure relief valves must be set to pressure relief/circulation to complete park operation.

**NOTE:** Electric transfer pumps will automatically park at the bottom of their stroke when the system is in Park mode.

7. Turn off the air compressor, air dryer, and breathing air.

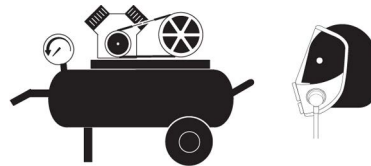

8. Turn the main power switch OFF.

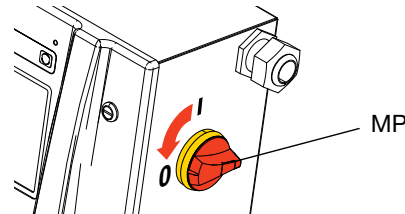

9. Close all fluid supply valves.

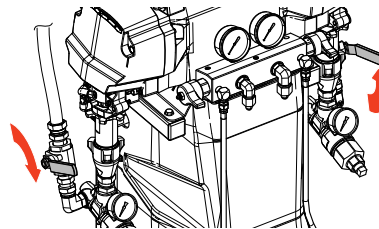

10. Set the pressure relief/spray valves (SA, SB) to

spray  to seal out moisture from the drain line.

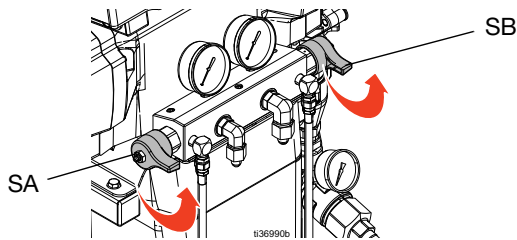

11. Engage the gun safety lock then close fluid manifold valves A and B.





# Flush the Equipment

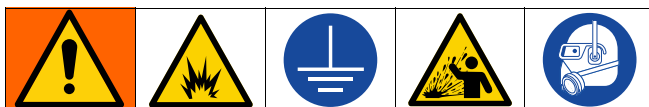

To help prevent fire and explosion:

- Flush equipment only in a well-ventilated area.
- Do not spray flammable fluids.
- Do not turn on heaters while flushing with flammable solvents.
- Always ground equipment and waste container.
- Flush out old fluid with new fluid, or flush out old fluid with a compatible solvent before introducing new fluid.
- Use the lowest possible pressure when flushing.
- All wetted parts are compatible with common solvents. Use only moisture-free solvents.

## To flush feed hoses, pumps, heaters, hose, and gun manifold:

1. Install bleed lines between the outlet manifold recirculation fitting and a grounded metal waste container.
2. Route the circulation lines back to respective solvent A or B supply. or grounded metal waste containers.
3. Set the pressure relief/spray valves (SA, SB) to

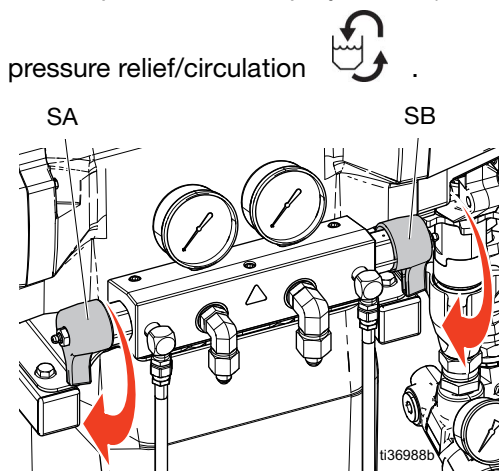

4. Use jog mode to circulate fluid. Reactor systems allow the entire system to be in jog mode, or A and

B-side transfer pumps to be put into jog mode separately. Refer to the jog mode instructions in your operations manual. Circulate fluid until only solvent comes from the bleed lines. The Reactor feed hoses, pumps, and heaters are now flushed.

5. Set the pressure relief/spray valves (SA, SB) to

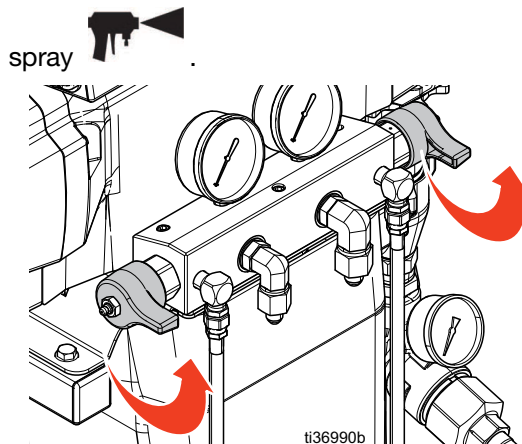

6. Hold the gun fluid manifold over two grounded waste containers. Open fluid valves XA and XB (see page 15) until only solvent flows from the valves. Close the valves. The Reactor hose and gun manifold are now flushed.

**NOTE:** For the estimated number of machine cycles needed to flush different models and hose configurations, see the table on page 22.

**Optional:** Use accessory circulation kit to circulate fluid through the gun manifold.

Circulation Kit	Gun	Manual in English
246362	Fusion AP, PC, MP	309818
256566	Fusion CS	313058

**NOTICE**

To prevent moisture from reacting with isocyanate, always leave the system filled with a moisture-free plasticizer or oil. Do not use water. Never leave the system dry. See **Important Isocyanate Information** on page 11.

# Repair

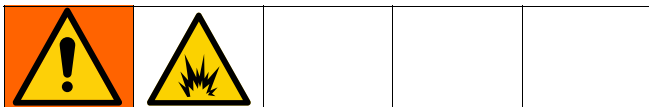

Repairing this equipment requires access to parts that may cause electric shock or other serious injury if work is not performed properly. Be sure to shut off all power to equipment before repairing.

## Before Beginning Repair

### NOTICE

Proper system setup, startup, and shutdown procedures are critical to electrical equipment reliability. The following procedures ensure steady voltage. Failure to follow these procedures will cause voltage fluctuations that can damage electrical equipment and void the warranty.

1. Flush if necessary. Follow **Flush the Equipment** on page 21.
2. Follow **Shutdown** on page 20.

## Flush Inlet Strainer Screen



The inlet strainers filter out particles that can plug the pump inlet check valves. Inspect the screens daily as part of the startup routine and clean as required.

Isocyanate can crystallize from moisture contamination or from freezing. If the chemicals used are clean and proper storage, transfer, and operating procedures are followed, there should be minimal contamination of the A-side screen.

Clean the A-side screen only during daily startup. This minimizes moisture contamination by immediately flushing out any isocyanate residue at the start of dispensing operations.

1. Follow the **Pressure Relief Procedure** on page 19.
2. Close the fluid inlet valve (XA) at the pump inlet and shut off the appropriate feed pump. This prevents material from being pumped while cleaning the screen.
3. Place a container under the strainer base to catch fluid when removing the strainer drain plug (ZB).
4. After fluid has drained, remove inlet cap (ZC) and inlet strainer screen (ZA) from the strainer manifold. Thoroughly flush the screen with compatible solvent and shake it dry. Inspect the screen. No more than 25% of the mesh should be restricted. If more than 25% of the mesh is blocked, replace the screen. Inspect the gasket and replace as required.
5. Install the strainer plug (ZB) with the screen (ZA).
6. Open the fluid inlet valve (XA), then ensure that there are no leaks, and wipe the equipment clean. Proceed with operation.

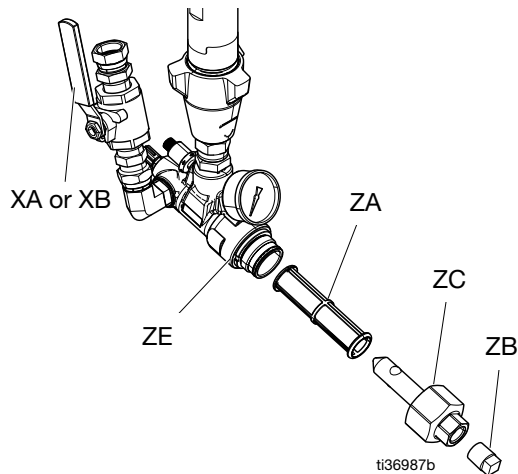

## Change ISO Pump Throat Seal Lubricant (TSL) Fluid

Check the condition of the TSL fluid daily. Change the TSL fluid if it becomes a gel, its color darkens, or it becomes diluted with isocyanate.

Gel formation is due to moisture absorption by the TSL fluid. The interval between changes depends on the environment in which the equipment is operating. The TSL fluid system minimizes exposure to moisture, but some contamination is still possible.

TSL fluid discoloration is due to continual seepage of small amounts of isocyanate past the pump packings during operation. If the packings are operating properly, TSL fluid replacement due to discoloration should not be necessary more often than every 3 or 4 weeks.

### To Change TSL Fluid:

1. Follow the **Pressure Relief Procedure** on page 19.
2. Lift the TSL fluid reservoir (R) out of the bracket and remove the reservoir from the cap. Hold the cap over a suitable waste container and flush contaminated fluid out of the lines by placing the strainer in the new fluid and dispense contaminated fluid through the return line into the waste container.
3. Manually cycle the peristaltic pump (PP) in the diagnostic screen until all contaminated TSL fluid is removed from the system.
4. Drain the reservoir and flush it with clean TSL fluid or replace it with a new reservoir.
5. When the TSL fluid system is flushed clean, fill it with fresh TSL fluid.
6. Thread the reservoir onto the cap (H) assembly and place it in the bracket.
7. Verify the TSL fluid pump is operating correctly by feeling the pulsation in the return hose during normal proportioner pump operation.

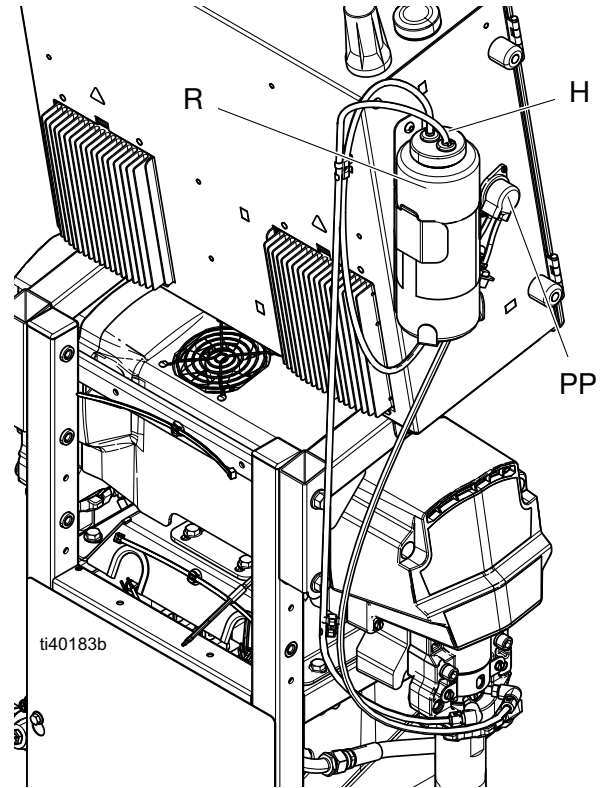

## Remove Pump



Pump rod and connecting rod move during operation. Moving parts can cause serious injury such as pinching or amputation. Keep hands and fingers away from connecting rod during operation.

**NOTE:** See your displacement pump manual for pump repair instructions.

1. Stop the pumps and turn off the heat zones.
2. Flush the pumps. Follow **Flush the Equipment** on page 21.
3. Relieve pressure. Follow the **Pressure Relief Procedure** on page 19.
4. Park and shutdown the Reactor. Follow **Shutdown** on page 20.
5. Turn main power switch (MP) off.

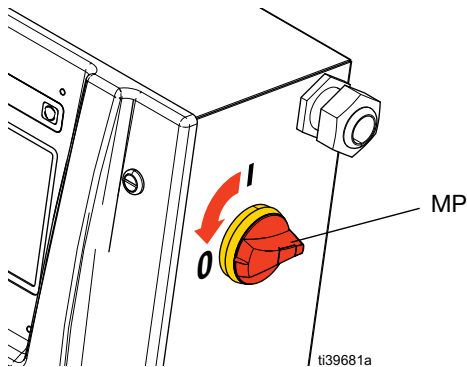

6. Route fluid to waste containers or supply tanks. Turn pressure relief/spray valves (SA, SB) to pressure relief/circulation.

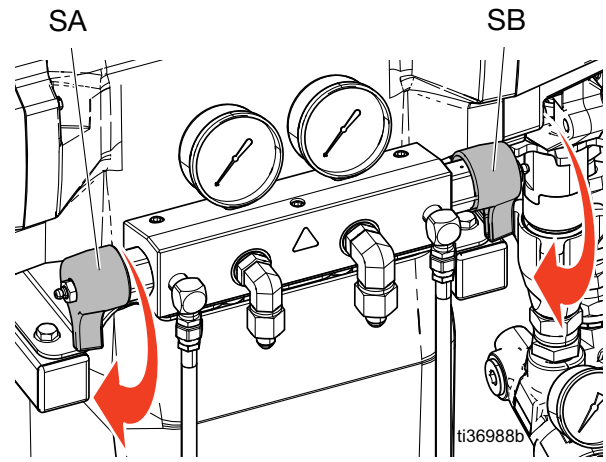

**NOTE:** Use a drop cloth or rags to protect the Reactor and surrounding areas from spills.

7. Disconnect fittings at fluid inlet (C) and outlet (D).
8. Also disconnect steel outlet hose from heater inlet.  
**NOTE:** Step 9 only applies to pump A. Skip this step if removing pump B.
9. Disconnect hoses (T). Remove both hose fittings (U) from wet-cup.
10. Remove cover (M).
11. Push the retaining wire clip (E) up. Push pin (F) out from the side of the pump facing the heaters. Loosen locknut (G) by hitting it firmly with a non-sparking hammer, then unscrew the pump.

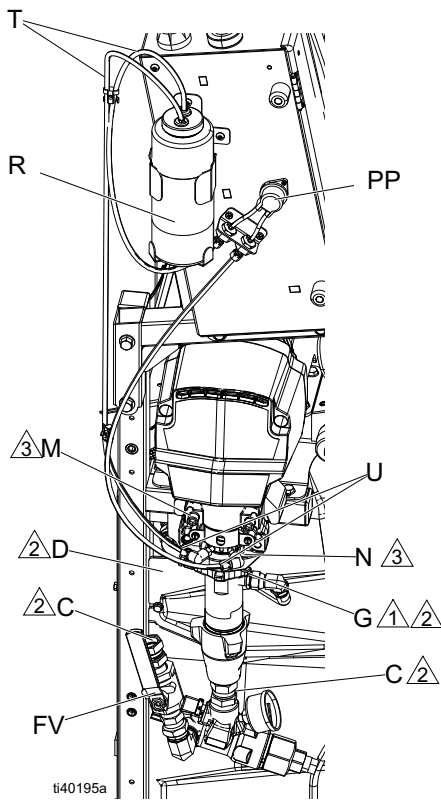

**Pump A**

ti40195a

- 1 Flat side faces up.
- 2 Lubricate threads with TSL fluid or Fusion grease.
- 3 Pump top threads must be nearly flush with bearing face (N).

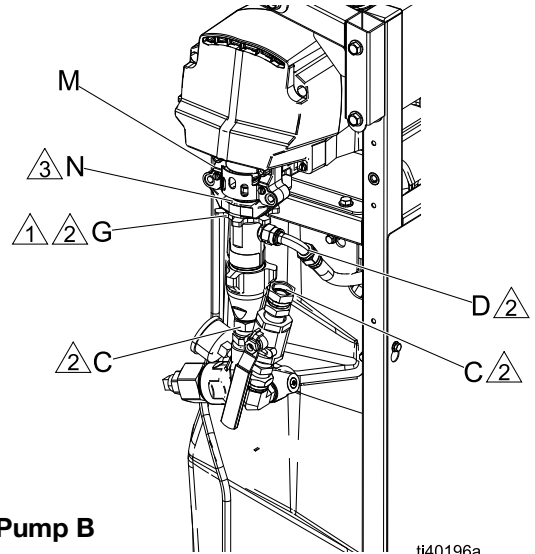

**Pump B**

ti40196a

- 1 Flat side faces up.
- 2 Lubricate threads with TSL fluid or Fusion grease.
- 3 Pump top threads must be nearly flush with bearing face (N).

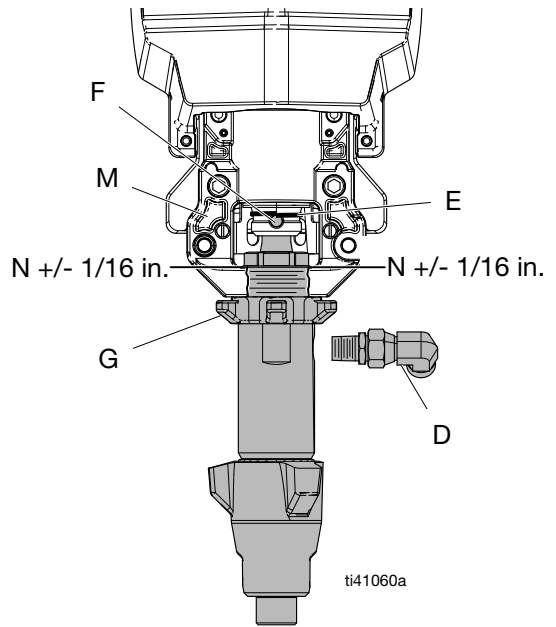

ti41060a

## Install Pump

**NOTE:** Steps 1–5 apply to pump B. To reconnect pump A, proceed to step 6.

1. Ensure locknut (G) is threaded onto the pump with the flat side up. Screw the pump into bearing housing (M) until the pin holes align. Push pin (F) in. Push the retaining wire clip (E) above the pin.

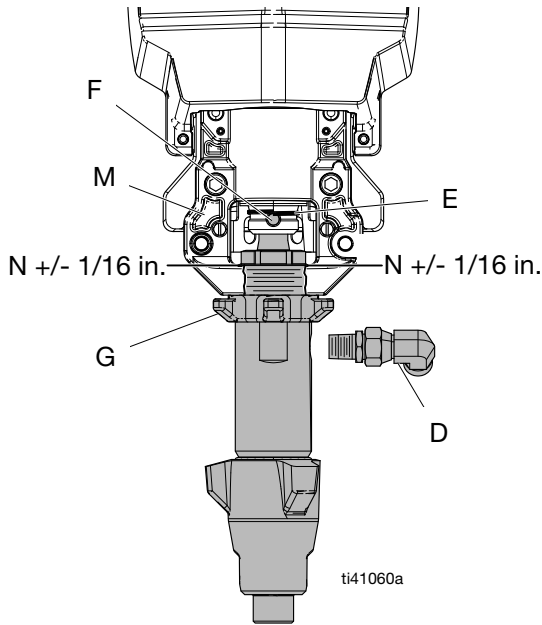

2. Continue threading the pump into the housing until fluid outlet (D) is aligned with the steel tube and top threads are +/- 1/16 in. (2 mm) of bearing face (N).
3. Tighten locknut (G) by hitting it firmly with a non-sparking hammer.

4. Reconnect fluid inlet (C) and outlet (D).
5. Proceed to step 13.

**NOTE:** Steps 6–12 apply to pump A only.

6. Ensure locknut (G) is threaded onto the pump with the flat side up. Carefully twist and extend displacement rod 2 in. (51 mm) above wet-cup.
  7. Start threading the pump into the bearing housing (M). When pin holes align, insert the pin. Pull the retaining wire clip down.
  8. Continue threading the pump into bearing housing (M) until the top threads are +/- 1/16 in. (2 mm) of bearing face (N). Ensure the barbed fittings at wet-cup flush ports are accessible.
  9. Connect the A-side outlet hose loosely at the pump and heater. Line up the hose, then tighten fittings securely.
  10. Tighten the locknut (G) by hitting it firmly with a non-sparking hammer.
  11. Apply a thin film of TSL fluid to barbed fittings. Using two hands, support hoses (T) while pushing straight onto barbed fittings. Secure each hose with a wire tie between two barbs.
- NOTE:** Do not let hoses kink or buckle.
12. Reconnect fluid inlet (C).
  13. Purge the air and prime the system. See your Reactor operation manual.

# Motor Replacement



## Tools Used:

- 5/16 and 3/16 in. nut driver
- 3/16 and 5/16 in. hex key
- 9/16 and 1/2 in. socket
- Phillips screwdriver
- 7/8 in. wrench

## Motor Removal

**NOTE:** The enclosure can remain upright for this procedure.

**NOTE:** See the image on the following page for part references.

1. Stop the pumps and turn off the heat zones.
2. Flush the pumps. Follow **Flush the Equipment** on page 21.
3. Relieve pressure. Follow the **Pressure Relief Procedure** on page 19.
4. Park and shutdown the Reactor. Follow **Shutdown** on page 20.
5. Turn the main power switch (MP) off.

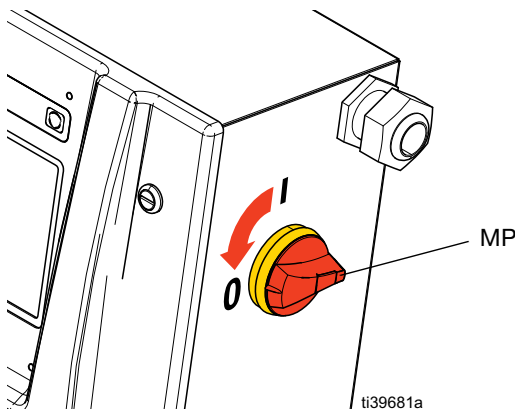

6. Use a 5/16 in. nut driver to remove screws (37) and side pump covers (7).

7. Use a 9/16 in. socket to remove bolts (24) and the top section of the lower cover (57).
8. Cut the zip ties inside and below the electrical enclosure (2). Cut the zip tie holding the hose wires to the outlet manifold (17).
9. Use a Phillips screwdriver to loosen the screws on the cable pass-through plate under the electrical enclosure (2). Disconnect connectors MCM #9, #14, and #15, then separate from the rest of the bundled cables.

**NOTICE**

To prevent a short circuit or lowering the transformer life, do not splash fluid on the transformer. Cover the transformer with a plastic sheet or piece of cardboard.

10. Disconnect and unplug heated hoses and recirculation lines, Disconnect the TSL compression fittings (44).
11. Disconnect pressure transducer cables under the outlet manifold (17).
12. Use a 3/16 in. hex key to remove bolts (60) from the outlet manifold and hang the manifold off the front of the machine. **NOTE:** Leave the fluid connections between the outlet manifold and heaters connected.
13. Use a 7/8 in. wrench to remove fluid connections from the heater to the B-side pump, then use a 5/16 in. hex key to remove bolts (110) from the B-side pump housing.
14. Remove the housing and set it aside.
15. Use a 3/16 in. nut driver to remove two screws (118) and remove the reed switch (119) from the bearing housing (106).
16. Use a 1/2 in. socket to remove five gear housing bolts (107), then remove the gear housing and set it aside.
17. Repeat steps 13-16 on the A-side pump.
18. Use a 1/2 in. socket, remove bolts (22) from the motor plate (3). **NOTE:** Secure the motor assembly before removing all four bolts.
19. Pull the motor plate straight out. Make sure all cables are free of snags and set the plate on a working surface.

20. Use a 5/16 in. nut driver to remove screws (37), then remove the motor cover (5).

**NOTE:** Before removing the motor from the motor plate, mark a line across the back of the motor plate where the motor rests. This will serve as a placement guide when installing the new motor.

21. Use a 1/2 in socket to remove bolts (22) and remove the motor from the motor plate.

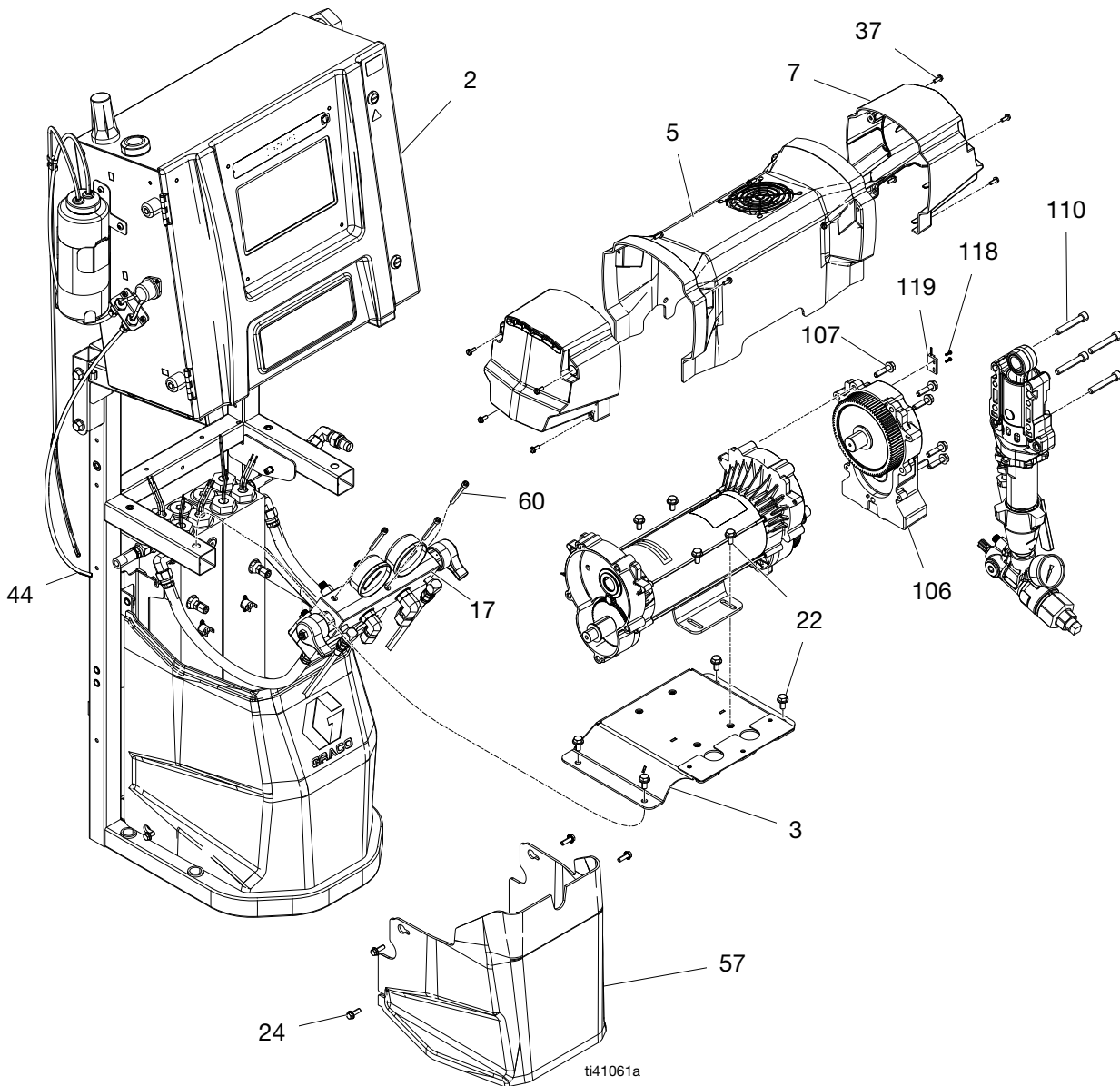
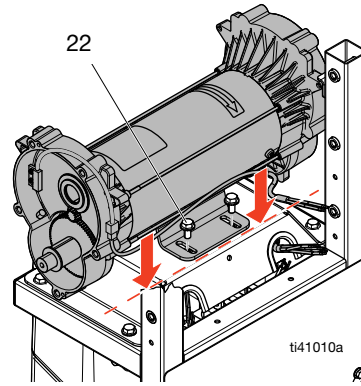



## Motor Installation

1. Place the motor on the motor plate and align it with the marking indicating the location of the previous motor.
2. Use a 1/2 in. socket to fasten bolts (22) and secure the motor to the motor plate. Use screws (37) to install motor cover (5). Make sure cables are routed out the back and the reed switch connector is routed as shown.

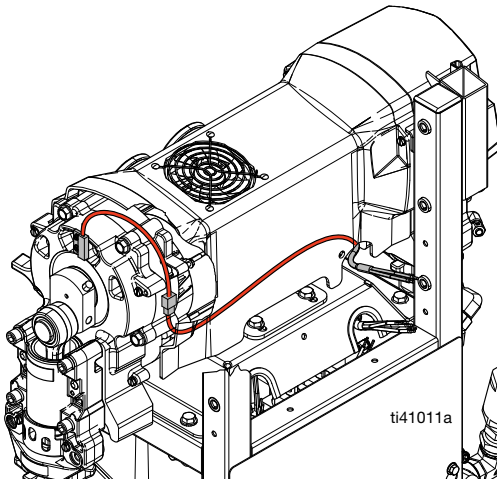

3. Place the motor plate on the frame (1) and partially hand thread all bolts (22). Once all bolts are started and the motor plate is aligned, tighten bolts (22).
4. Use a 1/2 in. socket to install the B-side gear housing with bolts (107) and torque to 200 in-lb (22.5 N•m).

**NOTE:** Install both gear housing cranks in the bottom dead-center positions. This will make sure that both pumps change over at the same time.

5. Use a 5/16 in. hex key to install the B-side pump housing with bolts (110) and torque to 25-30 in-lb (2.8-3.4 N•m). Use a 7/8 in. wrench to connect the fluid line (13) to the pump.
6. Repeat steps 3 and 4 on the A-side pump.
7. Install the reed switch on the B-side gear housing.
8. Place the outlet manifold on the motor bracket and use a 3/16 in. hex key to secure bolts (60). Reconnect the A-side pressure transducer cable to the A-side pressure transducer. Reconnect the B-side pressure transducer cable to the B-side pressure transducer. Reconnect the heated hose and recirculation lines.
9. Route the motor cables to the electrical enclosure (2) and connect to MCM ports #9, #14, and #15 as indicated by labels on the corresponding cables. See **Electrical Schematics** on page 69.
10. Slide the bottom pass-through plate to secure the opening and tighten.
11. Install side motor covers (7) using screws (37).

## Replace Circuit Breaker



1. Follow **Before Beginning Repair** on page 22.
2. Use an ohmmeter to check continuity across the circuit breaker (top to bottom). If there is no continuity, trip the breaker, then reset and retest it. If there is still no continuity, replace the breaker:
  - a. Refer to the circuit breaker table in **Electrical Schematics** on page 69.
  - b. Turn the main power switch (MP) off.

- c. Loosen the two screws connecting the wires and bus bar to the circuit breaker that will be replaced, then disconnect the wires.
- d. Pull the locking tab out 1/4 in. (6 mm) and pull the circuit breaker away from the din rail. Install the new circuit breaker. Insert the wires and tighten down all screws.

Circuit Breakers		
Ref.	Size	Component
CB1	40A	A (ISO) Heat
CB2	40A	B (RES) Heat
CB3	40A	Hose Transformer Primary
CB4	50A	Hose Heat
CB5	20A	Motor

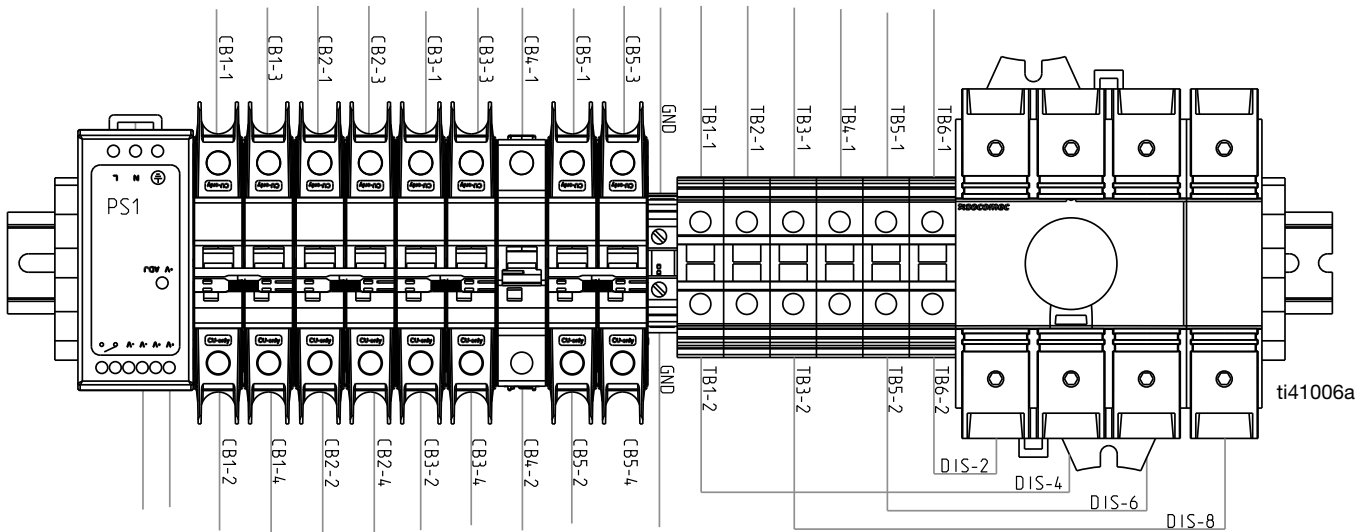
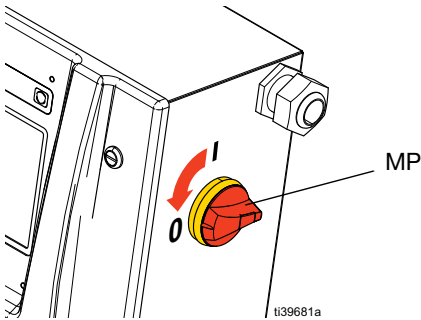

## Replace Inlet Pressure Transducer



**NOTE:** For Elite models only.

1. Follow **Shutdown** on page 20.
2. Follow the **Pressure Relief Procedure** on page 19.
3. Disconnect the inlet pressure transducer cable (RB) from the fluid inlet assembly. Inspect the cable for damage and replace if necessary. See **Electrical Schematics** on page 69.

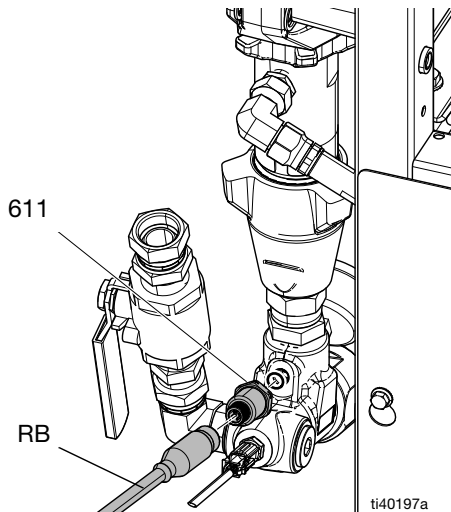

4. Replace the inlet pressure transducer cable:
  - a. Open the wire bundle and remove the inlet pressure transducer cable.
  - b. Cut any wire ties and disconnect from the MCM. See **Electrical Schematics** on page 69.

### NOTICE

To prevent cable damage, route and secure cable in the wire bundle with wire ties.

5. Replace inlet pressure transducer (611).
6. Connect the A-side inlet pressure transducer cable to MCM port #4. Connect the B-side inlet pressure transducer cable to MCM port #5.

## Replace Inlet Temperature Sensor



**NOTE:** For Elite models only.

1. Follow **Shutdown** on page 20.
2. Follow the **Pressure Relief Procedure** on page 19.
3. Disconnect the inlet temperature sensor cable (TB) from the fluid inlet assembly. Pull the tab to release the lock prior to removing the cable. Inspect cable for damage and replace if necessary. See **Electrical Schematics** on page 69.

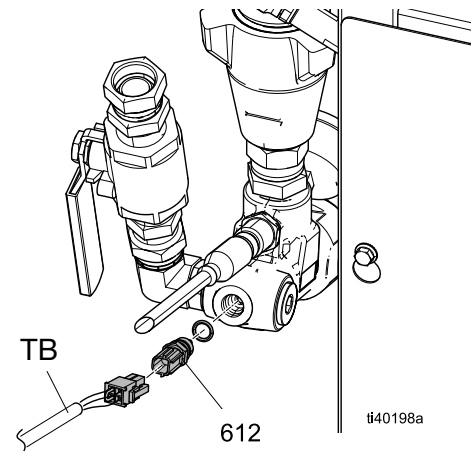

4. Replace the inlet temperature sensor cable:
  - a. Open the wire bundle and remove the inlet temperature sensor cable.
  - b. Cut any wire ties and disconnect from the TCM. See **Electrical Schematics** on page 69.

### NOTICE

To prevent cable damage, route and secure cable in the wire bundle with wire ties.

5. Replace inlet temperature sensor (612).
6. Connect the A-side inlet temperature sensor cable to TCM port #4, pins #1 and #2. Connect the B-side inlet temperature sensor cable to TCM port #4, pins #3 and #4.

## Replace Outlet Pressure Transducers



**NOTE:** For Elite models only.

1. Follow the **Pressure Relief Procedure** on page 19.
2. Follow **Shutdown** on page 20.
3. Disconnect outlet pressure transducer cables from #2 and #3 connectors on the MCM.
4. Remove wire ties constraining the outlet pressure transducer cables and remove the cables from the cabinet.
5. Apply thread sealant and install the new outlet pressure transducer (412).
6. Install the outlet pressure transducers into the manifold. Mark the end of the cable with tape (red = transducer A, blue = transducer B).
7. Route the new outlet pressure cables into the cabinet and re-thread the cable into the bundle. Re-attach the cable ties to the bundle.
8. Connect the A-side outlet pressure transducer cable to MCM port #2. Connect the B-side outlet pressure transducer cable to MCM port #3.

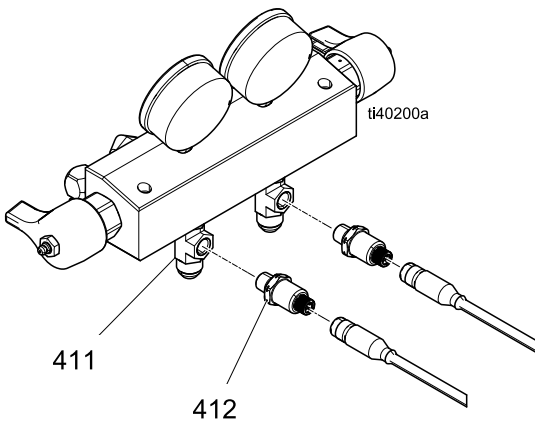

## Replace Fans

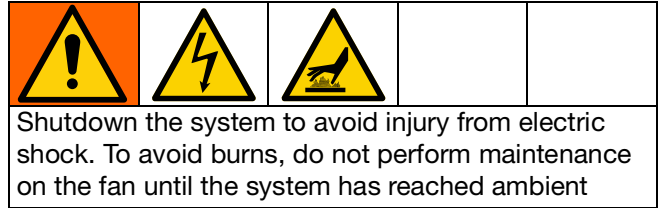

### Replace Motor Fan

Follow steps 1-22 from the **Motor Replacement** procedure on page 27, then follow steps 2-15 from the **Motor Installation** procedure on page 29.

### Alternative Motor Fan Replacement Procedure with Electrical Cabinet Folded Down

1. Follow **Shutdown** on page 20.
2. Open the electrical cabinet door and disconnect the fan cable from the MCM. See **Electrical Schematics** on page 69. Cut cable ties as needed.
3. Remove four screws (37) from the motor cover (5). If necessary, fold the frame (1) to remove the motor cover (5).
4. Install the new motor cover and route the fan cable up to the MCM.

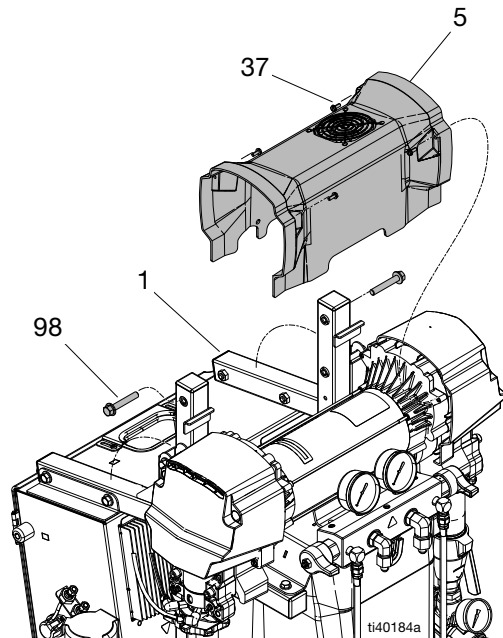

## Replace Transformer Fan



1. Follow **Shutdown** on page 20.
2. Remove bolts (24) and covers (57, 58).

3. Disconnect the transformer fan cable and remove the wire tie.
4. Remove four screws (39), finger guard (36), and the fan (10).
5. Install the new fan in reverse order, then secure the fan and replace the covers.

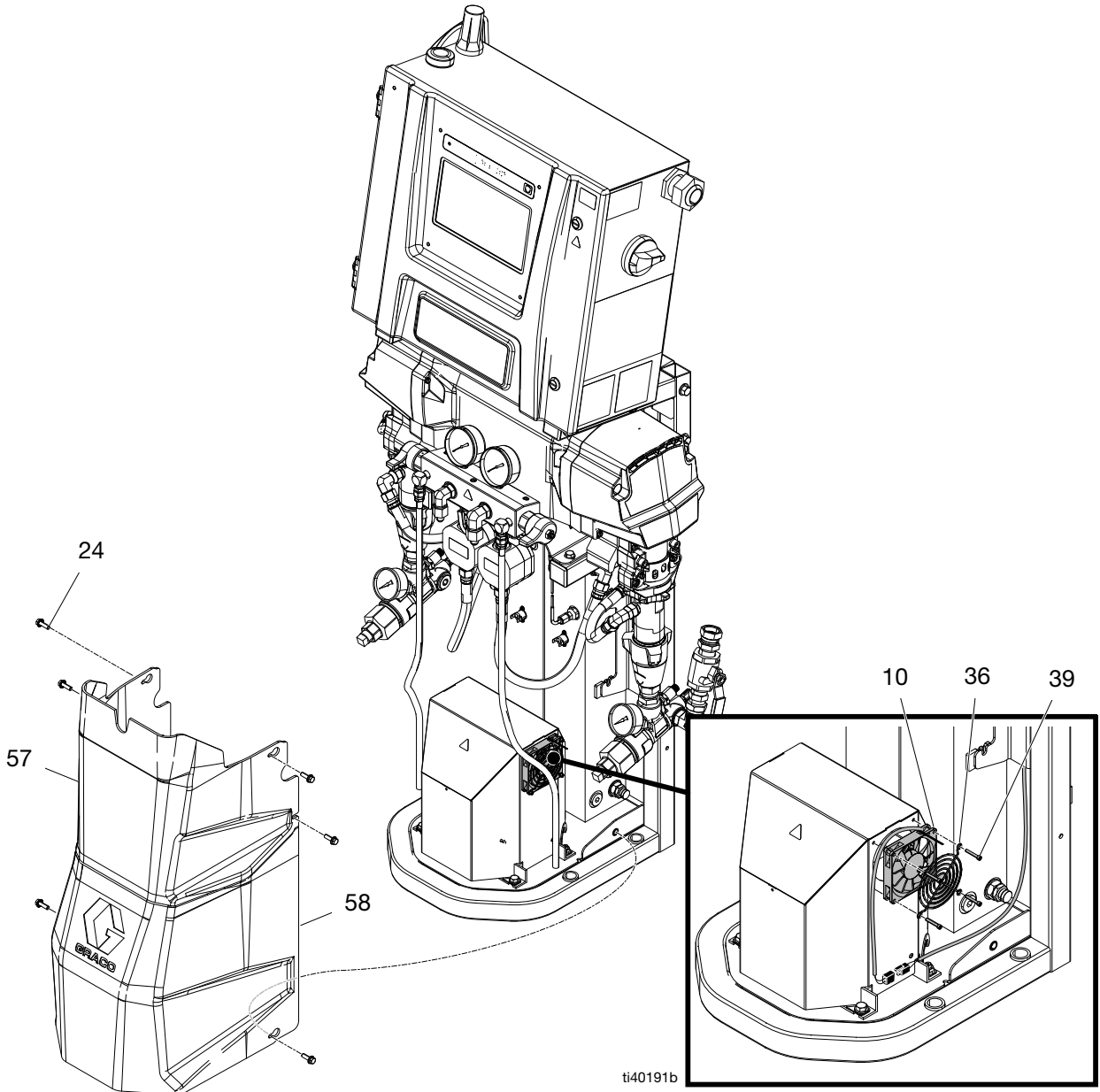

## Replace Flow Meter



**NOTE:** For Elite models only.

1. Follow the **Pressure Relief Procedure** on page 19.
2. Follow **Shutdown** on page 20.
3. Remove cover (57, 58).

4. Disconnect the flow meter cable.
5. Use two wrenches to disconnect hoses (40), then remove the flow meter (19) from manifold (17).
6. Install the new flow meter and reconnect the hose.
7. Reconnect the flow meter cable.
8. Enter the k-factor on the Pressure/Flow Setup screen in the ADM. Refer to **Setup Screen** in your Reactor 3 operation manual.

**NOTE:** The K-factor is printed on the flow meter label.

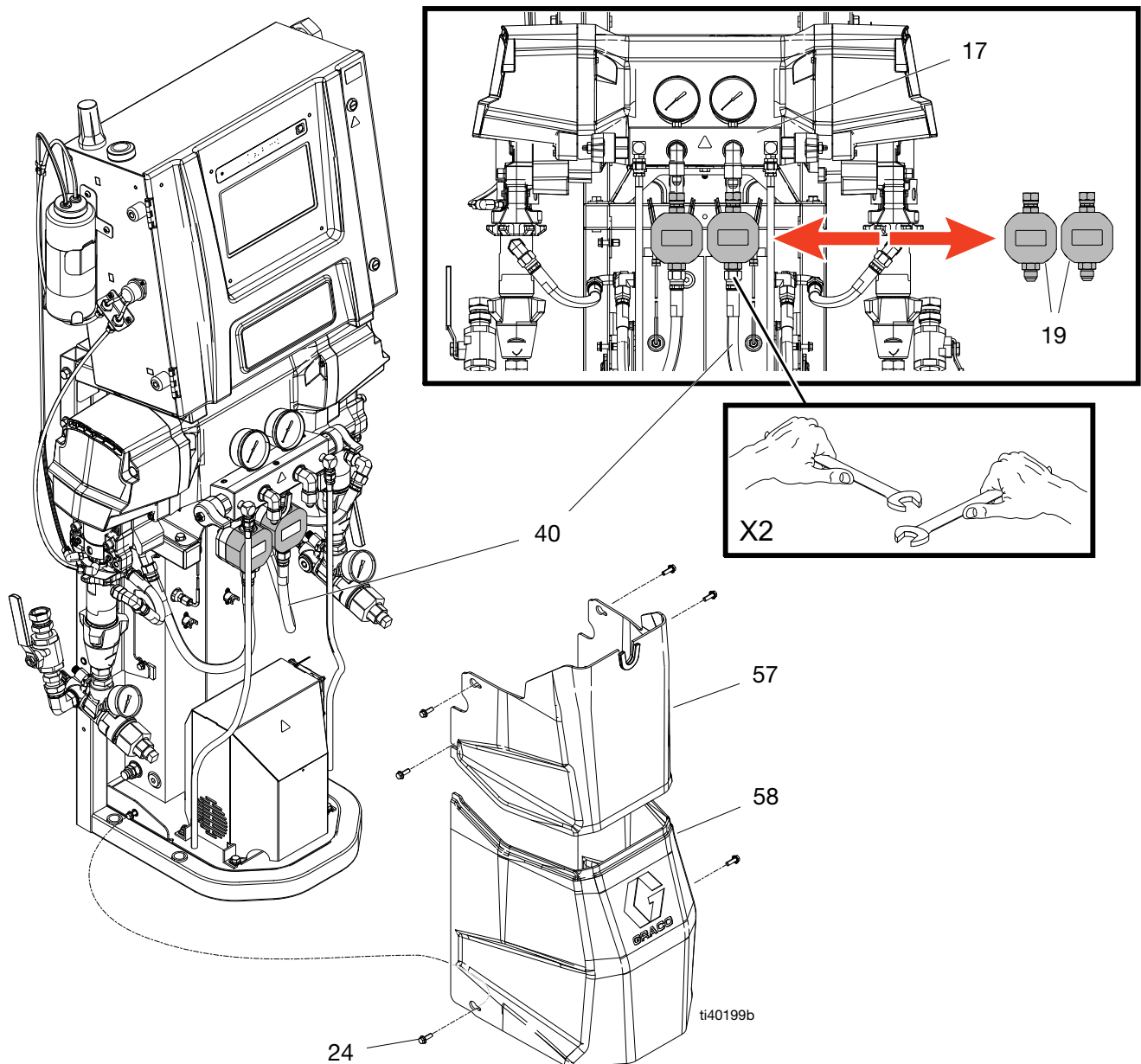



## Repair Primary Heater



### Replace Heater Element



1. Stop pumps and turn off heat zones.
2. Flush pumps. Follow **Flush the Equipment** on page 21.
3. Relieve pressure. Follow the **Pressure Relief Procedure** on page 19.
4. Park and shutdown the Reactor. See **Shutdown** on page 20.
5. Turn the main power switch (MP) off.

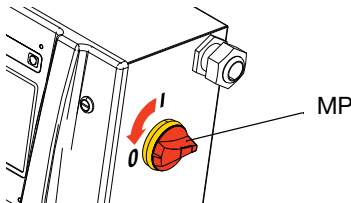

6. Wait for the heater to cool.
7. Remove the heater and RTD wires as needed from the TCM inside the enclosure and pull the wires through. See **Electrical Schematics** on page 69.

**NOTE:** The RTD should be replaced whenever replacing the outbound heater rod.

8. Use an ohmmeter to test the heater wires. See **Electrical Schematics** on page 69.
9. Disconnect over-temperature switch (214) from the cable.
10. Loosen ferrule nut (N). See page 40.
11. Remove RTD (212) from the heater housing. Do not remove adapter (206) unless necessary. If the adapter must be removed, make sure the mixer (210†) does not interfere when replacing the adapter.

12. Disconnect the inlet and outlet hoses from the heater and from the outlet manifold.
13. Remove two bolts (24) and lift the heater over the transformer.
14. Place the heater block (201) in a vise. Use a wrench to remove the heater element (203).
15. Inspect the heater element. It should be relatively smooth and shiny. Replace the element if there is a crusted, burnt, ash-like material adhered to the element, or if the sheath shows pitting marks.
16. Install the new heater element (203) while holding the mixer (210†) so it does not interfere with the RTD port.
17. Secure the heater to the frame with bolts (24).
18. Reinstall the RTD (212) in the heater block. See **Replace RTD** on page 35.  
**NOTE:** Replace the RTD whenever replacing the outbound heater rod.
19. Reconnect cable to the over-temperature switches (214).
20. Reconnect wires in electrical enclosure (2). See **Electrical Schematics** on page 69.

### Line Voltage

The heater outputs its rated wattage at 240 VAC. Low line voltage will reduce the power available. When this occurs, the heater will not perform at full capacity.

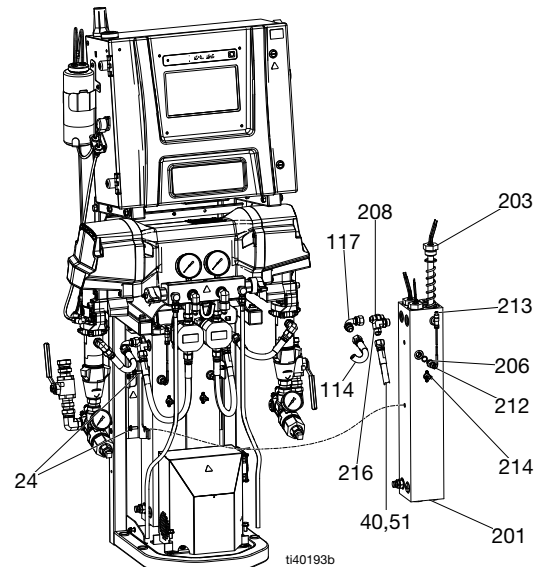

† Mixer (210) is visible on page 37.

## Replace Over-Temperature Switch



1. Follow **Shutdown** on page 20.
2. Wait for the heaters to cool.
3. Remove the lower covers (57, 58).

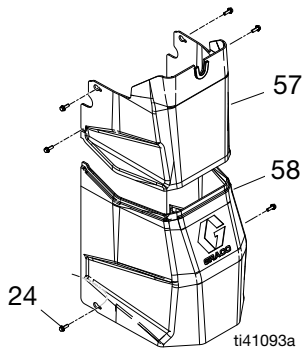

4. Disconnect over-temperature switches (214) from cable (49). Test across the spade terminals with an ohmmeter.
  - a. If the resistance is not approximately 0 ohms, the over-temperature switch needs to be replaced. Proceed to step 5.
  - b. If the resistance is approximately 0 ohms, inspect cable (49) to make sure it is not cut or open. Reconnect the over-temperature switch (214) and cable (49). Disconnect the cable from the TCM. Test from pin 1 to pin 2 and pin 3 to pin 4. See **Electrical Schematics** on page 69. If resistance is not approximately 0 and switches are 0, replace the original cable with a new one.

5. If the over-temperature switch fails the test, remove screws and discard the failed switch. Apply a thin layer of thermal compound 110009, then install a new switch in the same location on housing (201). Secure with screws (215) and reconnect the cables.

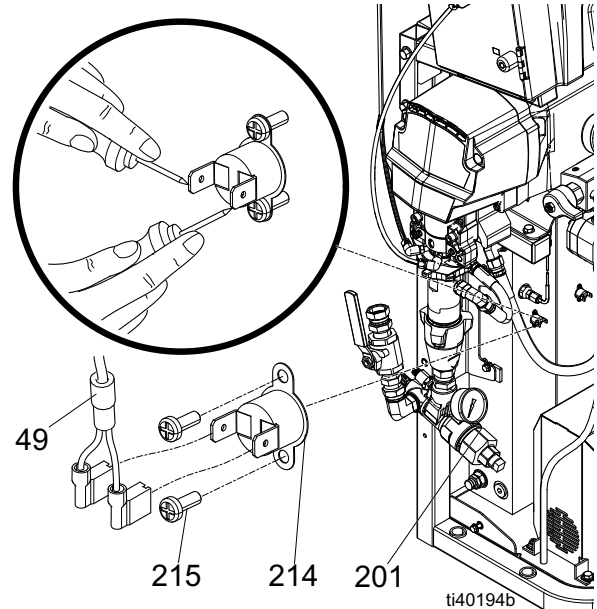



# Replace RTD



1. Follow **Shutdown** on page 20.
2. Follow the **Pressure Relief Procedure** on page 19.
3. Wait for the heaters to cool.
4. Remove the lower covers (57, 58).

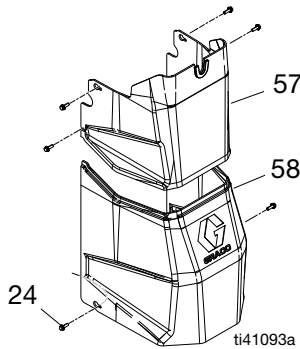

5. Cut the cable ties from around the woven wrap with the RTD cable (212).
6. Disconnect RTD cable (212) from TCM (453).

7. Loosen ferrule nut (N). Remove RTD (212) from RTD housing (H), then remove RTD housing (H). Do not remove the adapter (206) unless necessary. If the adapter must be removed, make sure the mixer (210) does not interfere replacing the adapter.
8. Remove the RTD cable (212) from the woven wrap.
9. Replace RTD (212):
  - a. Apply PTFE tape and thread sealant to the male pipe threads and tighten RTD housing (H) into the adapter (206).
  - b. Push in RTD (212) so the tip contacts the heater element (208).
  - c. Holding RTD (212) against the heater element, tighten the ferrule nut (N) 3/4 of a turn past finger-tight.
10. Route the wires as before through the woven wrap and reconnect the RTD cable (212) to the TCM.
11. Replace lower covers (57, 58).
12. Follow the startup instructions in the operation manual. Turn on A-side and B-side heat simultaneously to test. Temperatures should rise at the same rate. If one is low, loosen ferrule nut (N) and lightly tighten RTD housing (H) to make sure the RTD tip contacts element (212) when ferrule nut (N) is re-tightened.

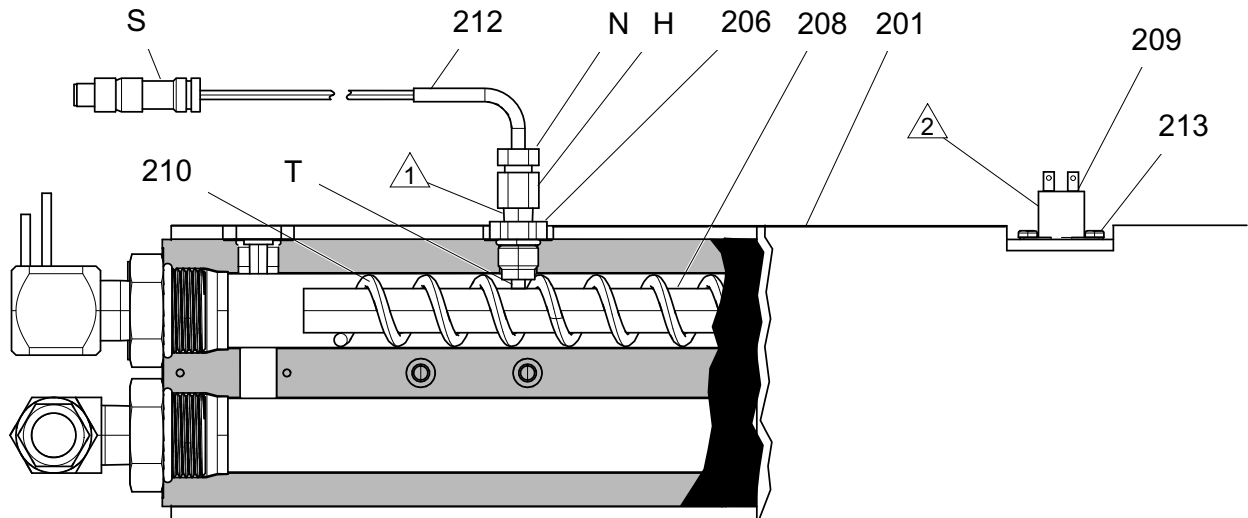

## Troubleshoot Heated Hose



Refer to your heated hose manual for replacement hose parts.

### Check Hose Wires for Continuity

1. Follow **Shutdown** on page 20.

**NOTE:** The whip hoses must be connected, otherwise the hose connectors at the end of the hose must be connected to each other.

2. Disconnect hose electrical connectors (D) at the Reactor.

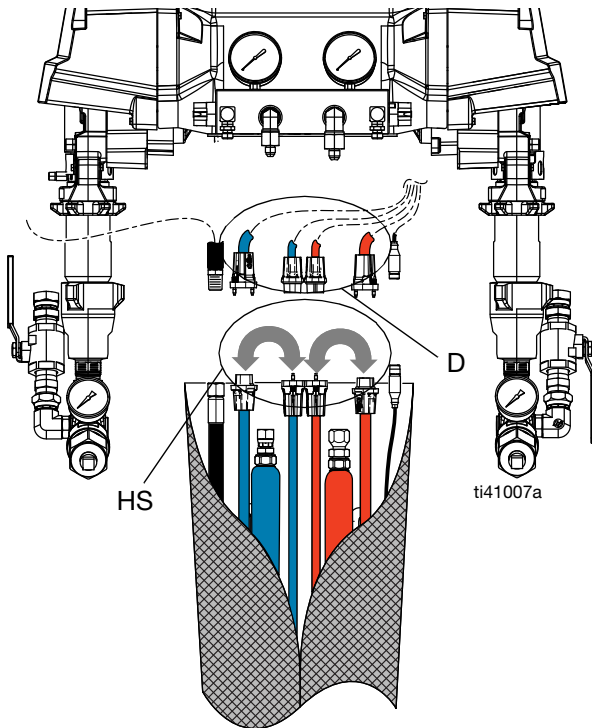

3. Test continuity between both sets (HS).
4. Use an ohmmeter to check between the hose wires. There should be continuity between both A (red) connectors and continuity between both B (blue) connectors.
5. If the hose fails the test, retest at each length of hose from the system out to the gun including whip hose, until the failure is isolated.
6. Replace the broken section of hose.

## Check Hose RTD Cables and FTS

1. Follow **Shutdown** on page 20.
2. Disconnect RTD cable (212) at the Reactor.
3. Test with an ohmmeter between the pins of cable connector.

**NOTE:** Do not touch the outer ring with the test probe.

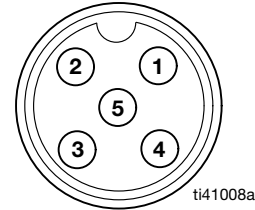

Pins	Result
1 to 3 and 4 to 3	See <b>RTD Resistance vs. Temperature</b> table on page 39. A-Side
1 to 5 and 4 to 5	See <b>RTD Resistance vs. Temperature</b> table on page 39. B-Side
1 to 4	0.2 - 0.4 ohms at the FTS (each 50 ft cable adds 0.75 ohms)
2 to any	Infinity (open)

4. Retest at each length of hose, including whip hose, until the failure is located.
5. If the FTS is not reading properly at the end of the hose, connect the FTS with the splitter directly to RTD cable (212) connected to the Reactor.

**NOTE:** You can also check each FTS independently with an ohmmeter between pins as shown below.

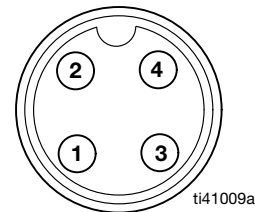

Pins	Result
1 to 3	See <b>RTD Resistance vs. Temperature</b> table on page 39. A-Side
4 to 3	See <b>RTD Resistance vs. Temperature</b> table on page 39. B-Side
1 to 4	0.2 - 0.4 ohms at the FTS
2 to any	Infinity (open)

- If the FTS reads properly at the Reactor but not at the end of the hose, check cable connections. Verify that connections are tight.

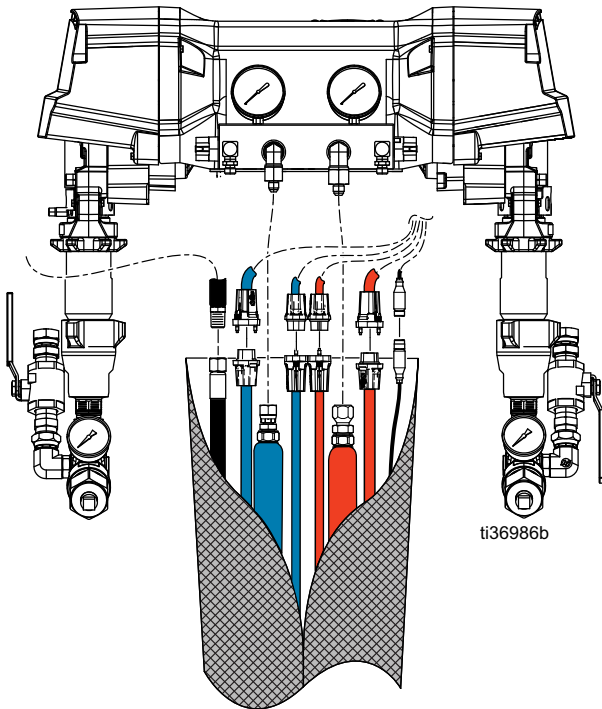

**NOTE:** To assist in taking readings, order RTD Test Kit 18E258. The kit includes two cables: one cable with a compatible female connector and another cable with a male connector. Both cables have stripped wire at the other end for easy test probe access. See the RTD Test Kit Wire Reference table.

### RTD Test Kit Wire Reference

Pins	Wire Color
1	Brown
2	Bare
3	Blue
4	Black
5	White

### RTD Resistance vs. Temperature

RTD or FTS Resistance Ohms	RTD or FTS Temperature °C (°F)
843	-40 (-40)
882	-30 (-22)
922	-20 (-4)
961	-10 (14)
1000	0 (32)
1039	10 (50)
1078	20 (68)
1117	30 (86)
1155	40 (104)
1194	50 (122)
1232	60 (140)
1271	70 (158)
1309	80 (176)
1347	90 (194)
1385	100 (212)

# Repair Fluid Temperature Sensor (FTS)

## Installation

The fluid temperature sensor (FTS) is an optional accessory. Install the FTS between two sections of hose. See your heated hose manual for details.

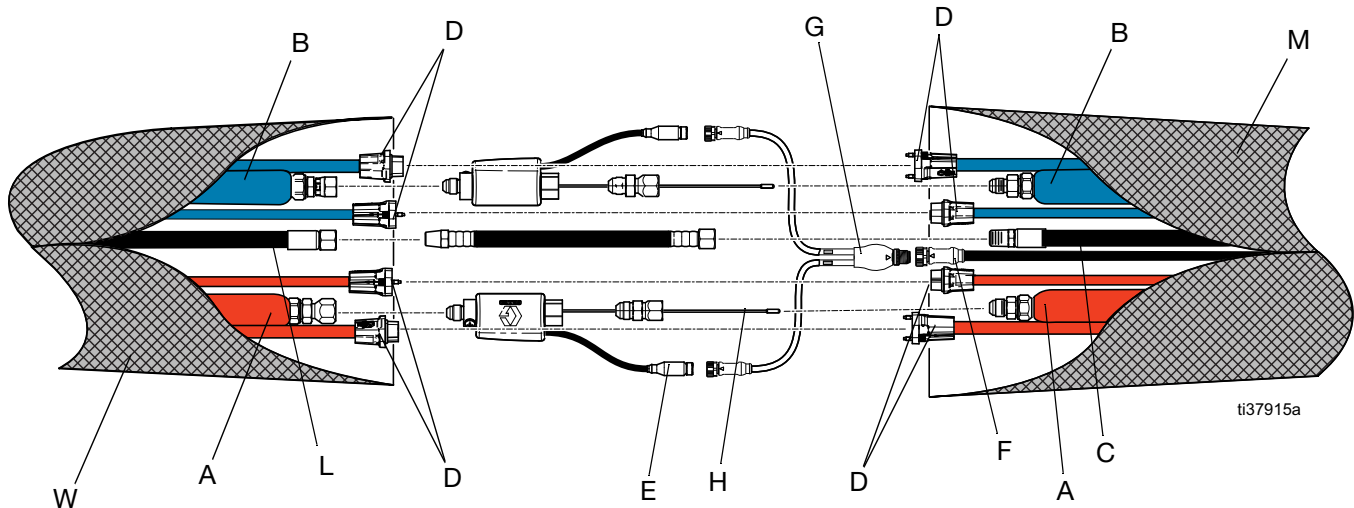

## Test / Removal



1. Relieve pressure. Follow the **Pressure Relief Procedure** on page 19.
2. Follow **Shutdown** on page 20.
3. Remove tape and protective covering from the FTS. Disconnect hose cable (F).
4. If the FTS is not reading properly at the end of the hose, see **Check Hose RTD Cables and FTS** on page 38.
5. If the FTS fails, replace the FTS or run it in resistance mode:
  - a. Disconnect air hoses (C, L) and electrical connection (D).
  - b. Disconnect A-side FTS fluid fittings from whip hose (W) and main hose (M).
  - c. Remove FTS probe (H) from the hose.
  - d. Repeat for B-side (RES).

## Calibration Procedure

### NOTICE

To prevent damage to the heated hose, a hose calibration is required if any of the following conditions are true:

- The hose has never been calibrated before
- A section of hose has been replaced
- A section of hose has been added
- A section of hose has been removed.

**NOTE:** The Reactor and heated hose must be at the same ambient temperature to get the most accurate calibration. Perform calibration at the beginning of the day before any material has been heated.

See your Reactor 3 operation manual for instructions on how to perform the calibration procedure.

## Transformer Check

See **Electrical Schematics** on page 69.

1. Follow **Shutdown** on page 20.
2. Check the transformer primary wires:
  - a. Open circuit breaker CB3 to turn the color indicator on the circuit breaker green.
  - b. Use an ohmmeter to test for continuity between the primary transformer wires in CB3-2 and CB3-4 (there should be continuity).
  - c. Close circuit breaker CB3 after the test.

3. Check the transformer secondary wires:
  - a. Disconnect the 7-pin green connector (PI-TCM) from the TCM.
  - b. Use an ohmmeter to test for continuity between terminals 5 and 6 on the TCM 7-pin green connector. There should be continuity. If there is no continuity, check the transformer.
  - c. Reconnect the 7-pin green connector to the TCM.
4. Check the transformer:
  - a. Apply incoming power to the system.
  - b. To verify voltage on the secondary leads of the transformer, measure between terminals 5 and 6 on the TCM 7-pin green connector. Verify voltage is approximately 90 VAC (E-30 and E-XP2) or 60 VAC (E-20 and E-XP1) for 240 VAC input.
  - c. See the diagnostic Run Screen on the ADM. The diagnostic run screen displays the incoming voltage to the TCM under “Voltages”.

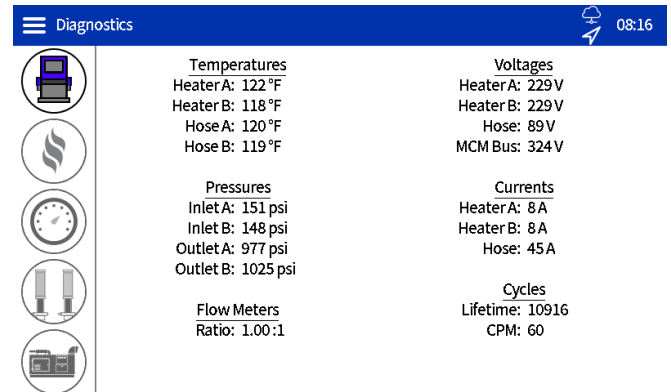

- d. If the hose current is zero (0) when heating the hose (see “Currents” and “Hose” on the diagnostic screen). Make sure breaker CB4 is not tripped.

## Replace Transformer



1. Follow **Shutdown** on page 20.
2. Remove bolts (24) and covers (57, 58).

3. Remove transformer cover (9).
4. Disconnect transformer connections from terminal blocks. Connections are labeled: 1, 2, 3, and 4.
5. Remove transformer (8).
6. Install transformer (8) in reverse order.

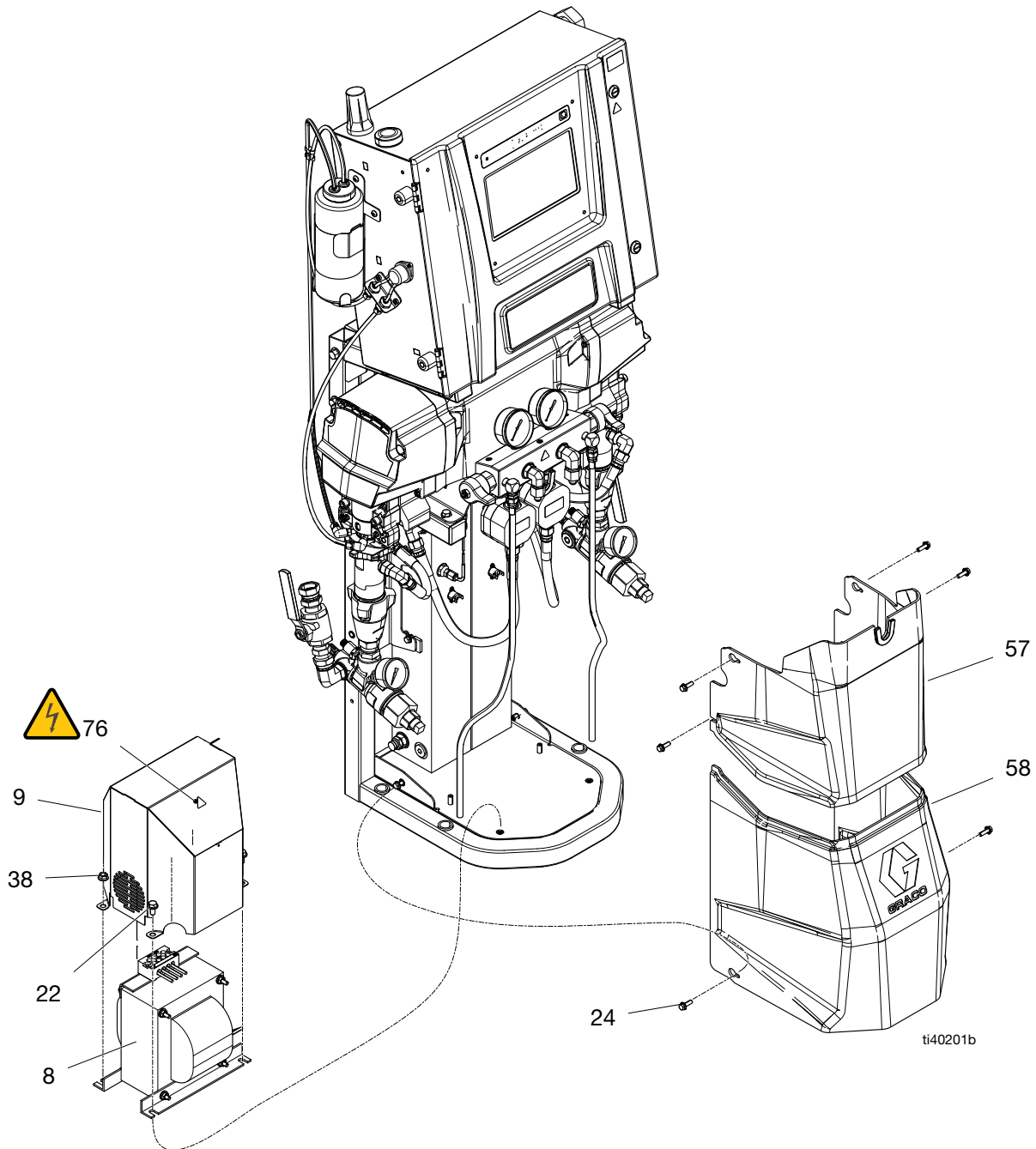

## Replace Power Supply



1. Follow **Shutdown** on page 20.
2. Disconnect input and output cables from both sides of the power supply. See **Electrical Schematics** on page 69.
3. Insert a flathead screwdriver in the mounting tab on the power supply to remove from the din rail.
4. Install new power supply (706) in reverse order.

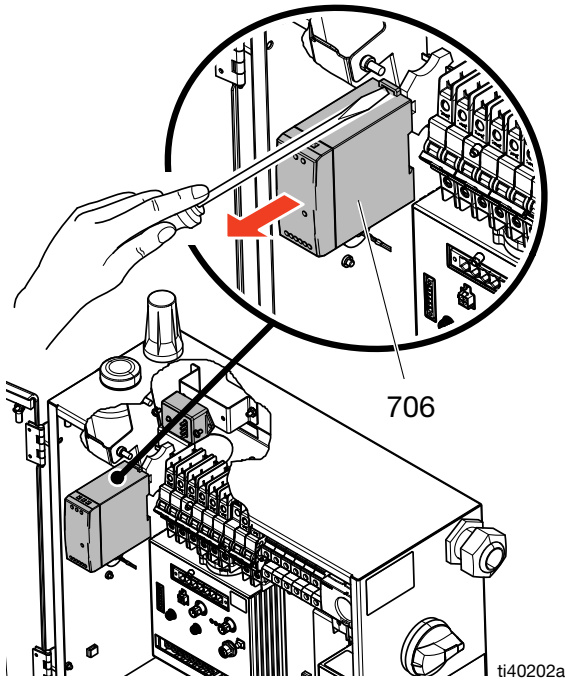

ti40202a

## Replace Surge Protector



1. Follow **Shutdown** on page 20.
2. Loosen connections on terminals 1 and 3 on CB3. See **Electrical Schematics** on page 69.
3. Loosen connections on input to power supply (706) on N and L connections. See **Electrical Schematics** on page 69.
4. Remove two screws (510) and the surge protector (AAF) from the enclosure.
5. Install the new surge protector (AAF) in reverse order.

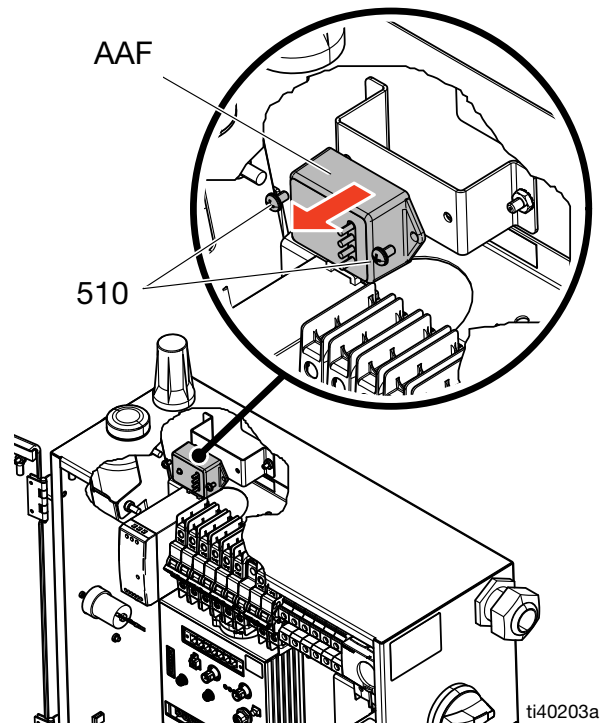

ti40203a

## Replace Motor Control Module (MCM)



1. Follow **Shutdown** on page 20.
2. Disconnect connectors from MCM (505). Disconnect two power cables. See **Electrical Schematics** on page 69.
3. Remove nuts (508) and MCM (505).
4. Replace the MCM in the enclosure.
5. Connect the cables to the MCM. See **Electrical Schematics** on page 69.

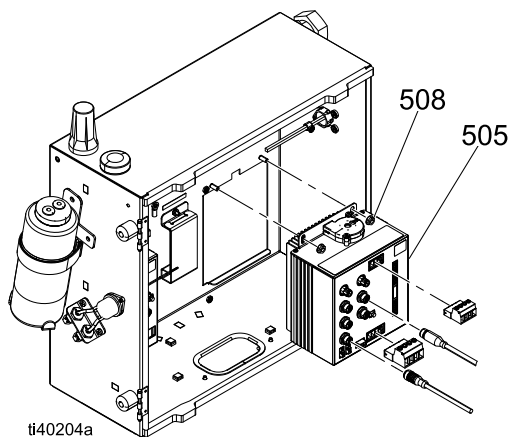

6. On the next power cycle, set the system type (E-20, E-30, etc) on the ADM.

## Replace Temperature Control Module (TCM)



1. Follow **Shutdown** on page 20.
2. Disconnect all connectors from the TCM (503). See **Electrical Schematics** on page 69.
3. Remove two nuts (508) and TCM (503).
4. Replace the TCM in the enclosure.
5. Connect cables to the TCM. See **Electrical Schematics** on page 69.

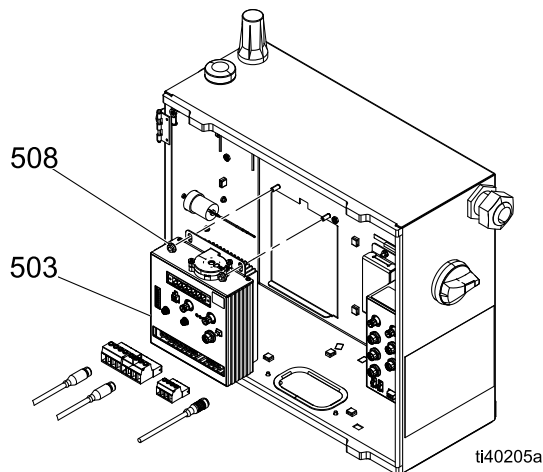



## Replace Advanced Display Module (ADM)



1. Follow **Shutdown** on page 20.
2. Disconnect the CAN cable and cellular cable. See **Electrical Schematics** on page 69.
3. Loosen four screws (507) on the inside of the electrical enclosure door. Remove ADM (528).
4. Replace the ADM in the enclosure door.

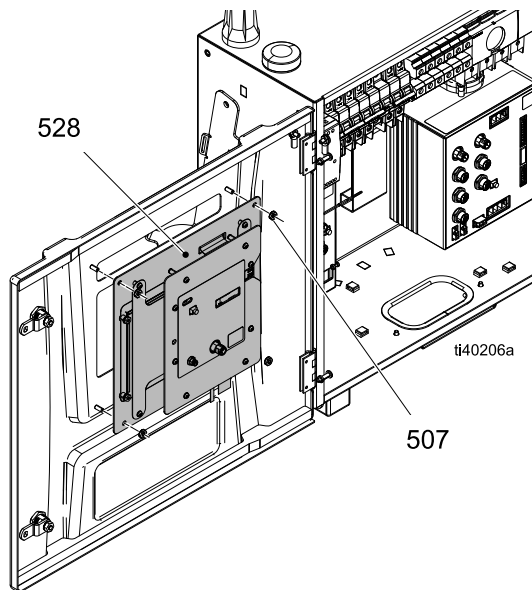

5. Connect the CAN cable and cellular cable. See **Electrical Schematics** on page 69.
6. If necessary, update the software by installing a USB drive with the latest software into the ADM. Follow the **Software Update Procedure USB** on page 46.

## Software Update Procedure

ADM repair kit modules are shipped pre-programmed and with upgrade USB drive number 15N423. If the software version upgrade is necessary, follow the **Software Update Procedure USB** on page 46.

# Software Update Procedure USB



1. Download the latest software into the top directory of a USB drive. The software can be downloaded from help.graco.com.

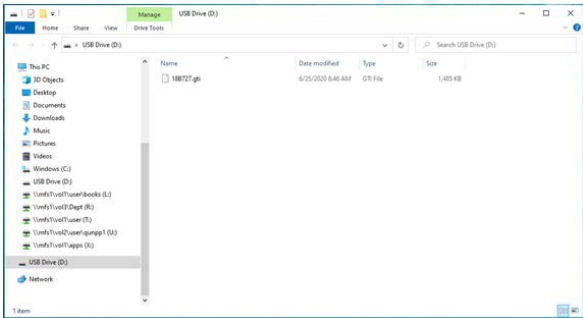

2. Follow **Shutdown** on page 20 or turn off main disconnect switch. Insert the USB, then close the enclosure door. Turn on main disconnect switch.

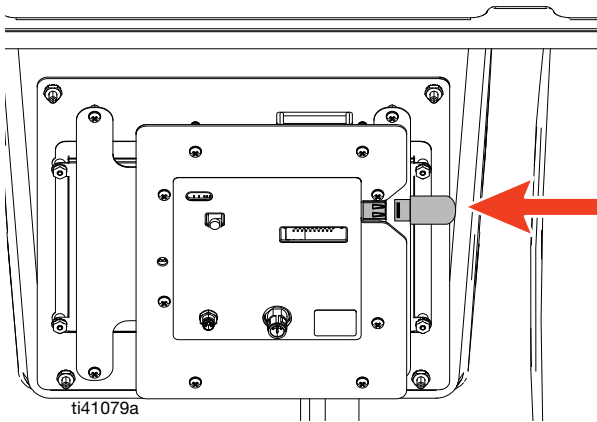

3. The home screen will load and show the USB icon in the top right corner.

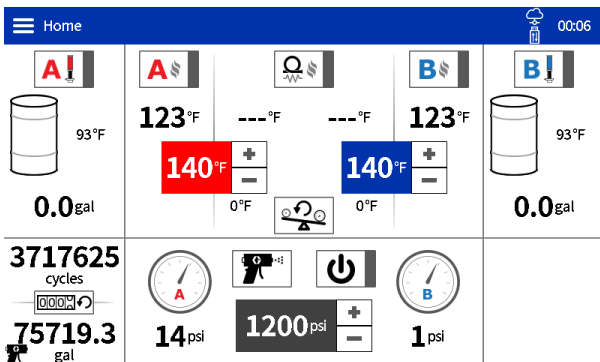

4. After the .GTI file has downloaded to the Reactor, a prompt will appear asking to apply the update on the next power cycle.

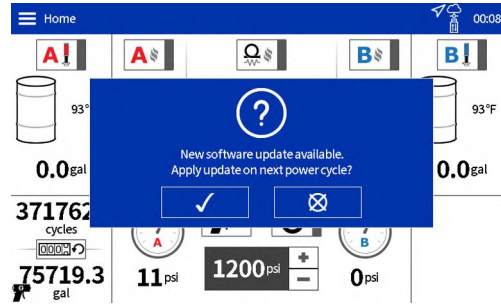

5. Press the check mark and wait for the on-screen prompt to prepare the Reactor for the update on the next power cycle.
6. After step 5 is complete, the home screen will show a circle with arrows in the right corner of the menu bar. This indicates that the software will be updated on the next power cycle.

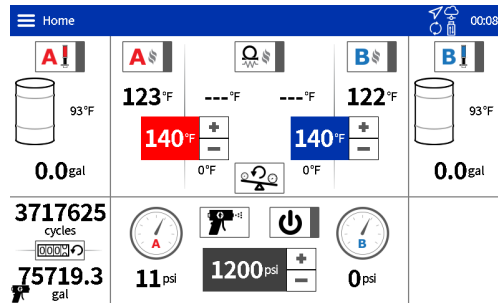

7. Cycle the power by turning the disconnect switch off then back on. Wait for the update to complete. Confirm the software update is complete by pressing the check mark.
8. The Software Update Complete screen will appear. Use the QR code displayed on screen to access the software release notes. Otherwise, press the check mark to return to the home screen. Follow **Shutdown** on page 20 or turn off main disconnect switch, remove the USB, then close the enclosure door. Turn on the main disconnect switch to continue operation.



## Over-the-Air Software Updates

Pro and Elite models with cellular modules installed have the ability to perform software updates wirelessly. If this feature is desired, the Enable Cellular Software Update setting on the ADM must be selected. This setting is available on the Advanced > Software screen. See your Reactor operation manual for a description of ADM settings.

New software will download in the background when available. Once the download is complete, a prompt to update software on the next power cycle will appear.



Press the check mark and the update will be applied on the next power cycle.

## Replace Fluid Outlet Manifold



The fluid outlet manifold is the assembly where the heated hoses connect to the unit. The assembly contains pressure gauges as well as pressure transducers and dump valves on either side in order to circulate material back to the drums.

1. Follow the **Pressure Relief Procedure** on page 19).
2. Follow **Shutdown** on page 20.
3. Remove covers (57, 58).

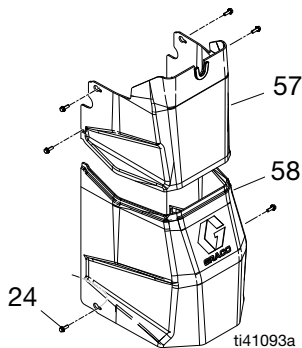

### NOTICE

To prevent a short circuit or lowering the transformer life, do not splash fluid on the transformer. Cover the transformer with a plastic sheet or piece of cardboard.

4. Disconnect fluid lines (40) (or flow meters on Elite models), heated hose, and recirculation lines (55) from the outlet manifold (17).

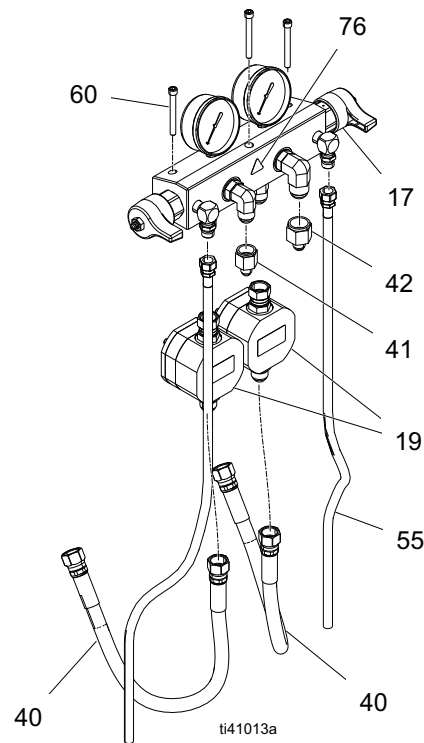

5. Disconnect the outlet pressure transducer cables from transducers.
6. Use a 3/16 in. hex key to remove screws (60), then remove the manifold (17).
7. When installing the new manifold, place the gasket (61) in approximately the same location on the motor bracket (3). Use the mounting holes to align, then place the new manifold on top and re-install the screws (60).
8. Re-connect fluid lines (40) and recirculation lines (55) to corresponding fittings and outlet pressure transducer cables to the transducers.
9. Re-install the covers (57, 58).

# Parts

## Top Level Units

### 26R342 Parts

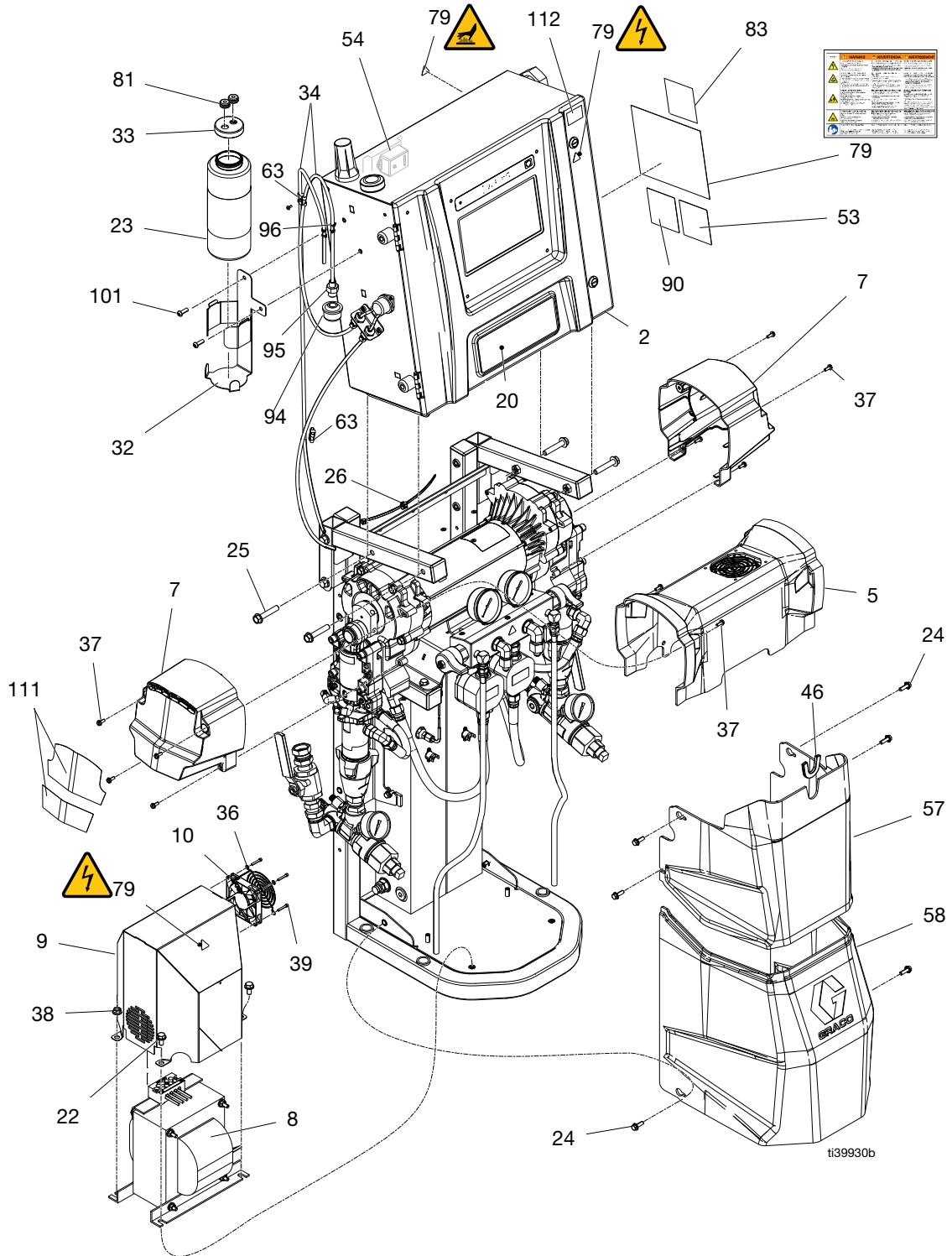

### 26R342 Parts

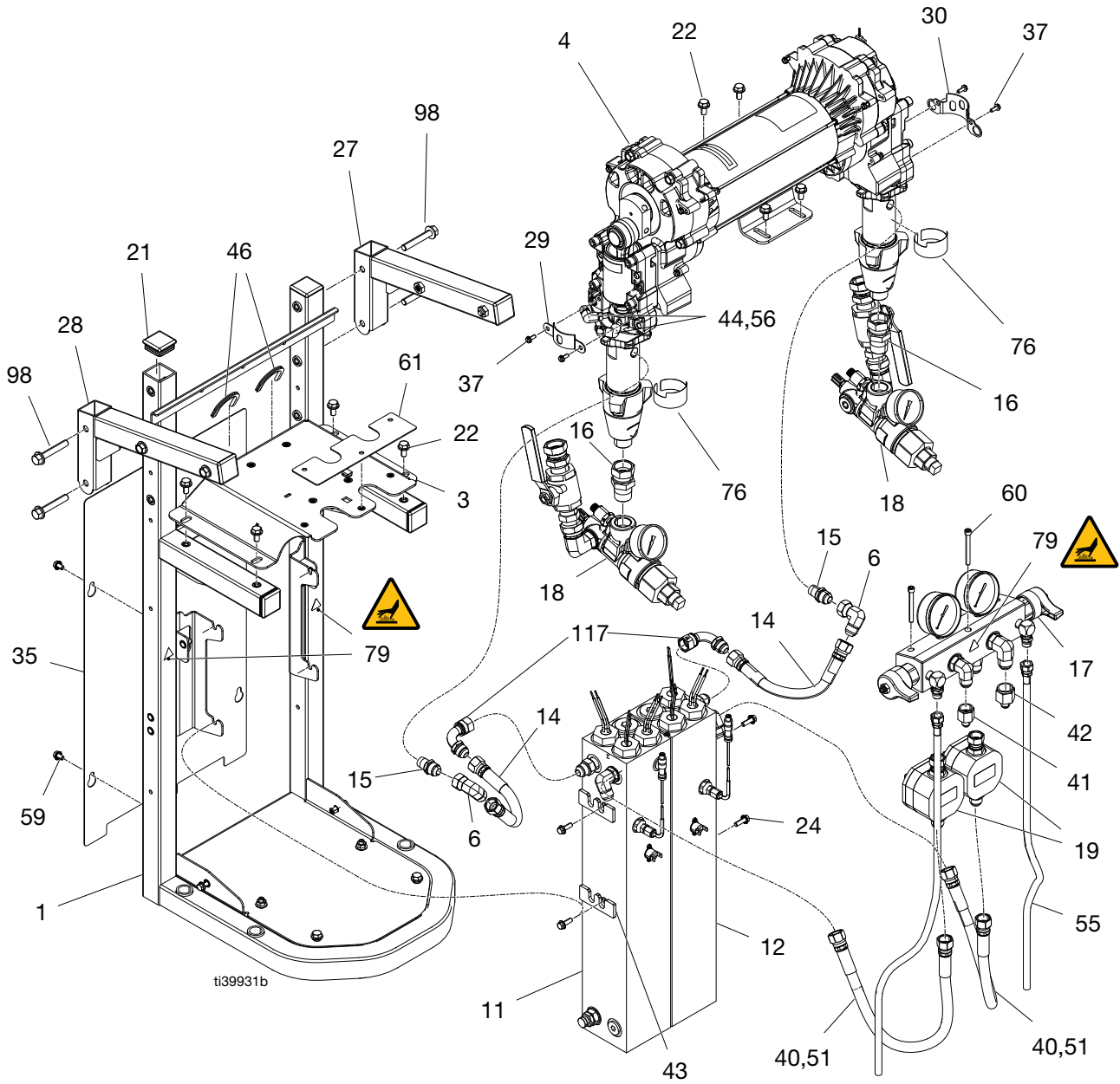

## 26R342 Parts List

Ref.	Part	Description	Qty.														
			26R310	26R311	26R312	26R313	26R320	26R321	26R322	26R330	26R331	26R332	26R333	26R340	26R341	26R342	
1	-----	FRAME, weldment, R3, painted	1	1	1	1	1	1	1	1	1	1	1	1	1	1	1
2	-----	ENCLOSURE, elec, r3, no-app, 6-15 kW	1				1			1				1			
	-----	ENCLOSURE, elec, r3, w/app, 6-15 kW		1	1	1		1	1		1	1	1		1	1	
3	-----	BRACKET, proportioner, painted	1	1	1	1	1	1	1	1	1	1	1	1	1	1	
4	-----	PROPORTIONER, module, E-20, (see <b>Drivers Parts</b> on page 54)	1	1	1	1	1	1	1								
	-----	PROPORTIONER, module, E-30, (see <b>Drivers Parts</b> on page 54)								1	1	1	1				
	-----	PROPORTIONER, module, E-XP2, (see <b>Drivers Parts</b> on page 54)												1	1	1	
5	18E190	COVER, motor, fan, assembly	1	1	1	1	1	1	1	1	1	1	1	1	1	1	
6	16W608	FITTING, elbow 8 jic swivel x 8 jicm	1	1	1	1	1	1	1	1	1	2	2	2	2	2	
7	24V023	COVER, front, 695, painted	2	2	2	2	2	2	2								
	24V024	COVER, front, plastic, painted								2	2	2	2	2	2	2	
8	18E131	TRANSFORMER, 4090va, 230/90								1	1	1	1	1	1	1	
	18E130	TRANSFORMER, 2790va, 230/62	1	1	1	1	1	1	1								
9	18E202	COVER, weldment, transformer	1	1	1	1	1	1	1	1	1	1	1	1	1	1	
10	132561PKG	FAN, 24 VDC, 80 mm square x 15 mm	1	1	1	1	1	1	1	1	1	1	1	1	1	1	
11	18E145	HEATER, assy, 1-zone, a-side, 7.2 kW										1	1	1	1	1	
	18E142	HEATER, assembly, dual-zone, 7.6 kW	1	1													
	18E141	HEATER, assembly, dual-zone, 9.6 kW			1	1	1	1	1	1	1						
12	18E146	HEATER, assy, 1-zone, b-side, 7.2 kW										1	1	1	1	1	
14	18E205	HOSE, coupled, R3, fluid, -8 jic	2	2	2	2	2	2	2	2	2	2	2	2	2	2	
15	121311	FITTING, connector, npt x jic								2	2	2	2	2	2	2	
	121310	FITTING, connector, npt x jic	2	2	2	2	2	2	2								
16	118459	FITTING, union, swivel, 3/4 in.	2	2	2	2	2	2	2					2	2	2	
	16W967	FITTING, swivel, 3/4 npt x 1 npsm								2	2	2	2				
17	18E207	HOUSING, outlet, assembly		1	1	1		1	1		1	1	1		1	1	
	18E208	HOUSING, outlet, assembly	1				1			1				1			
18	18E246	STRAINER, R3, assembly, pair, pro		1		1		1			1		1		1		
	18E247	STRAINER,R3, assembly, pair, elite			1				1			1				1	
	18D520	KIT, accessory, inlet pair								1							
	18D475	KIT, accessory, inlet pair	1				1							1			
19	18E136	METER, flow, R3, high pressure			2				2			2				2	
20	-----	LABEL, brand								1	1	1	1				
	-----	LABEL, brand	1	1	1	1											
	-----	LABEL, brand					1	1	1								
	-----	LABEL, brand												1	1	1	
21	-----	CAP, hose, square	6	6	6	6	6	6	6	6	6	6	6	6	6	6	
22	111800	SCREW, FL hex head, 5/16-18 x 5/8	10	10	10	10	10	10	10	10	10	10	10	10	10	10	
23	25T859	FLUID, TSL, 25 oz (750 ml)	2	2	2	2	2	2	2	2	2	2	2	2	2	2	
24	113796	SCREW, FL hex head, 1/4-20 x 3/4	10	10	10	10	10	10	10	10	10	10	10	10	10	10	
25	111194	SCREW, FL hex head, 3/8-16 x 2	4	4	4	4	4	4	4	4	4	4	4	4	4	4	

Parts

Ref.	Part	Description	Qty.													
			26R310	26R311	26R312	26R313	26R320	26R321	26R322	26R330	26R331	26R332	26R333	26R340	26R341	26R342
26†	-----	TIE, cable, fir tree	6	6	6	6	6	6	6	6	6	6	6	6	6	6
27	-----	BRACKET, pivot, right, R3, painted	1	1	1	1	1	1	1	1	1	1	1	1	1	1
28	-----	BRACKET, pivot, left, R3, painted	1	1	1	1	1	1	1	1	1	1	1	1	1	1
29	19Y569PKG	SHIELD, pump rod	1	1	1	1	1	1	1	1	1	1	1	1	1	1
30	15C762PKG	SHIELD, pump rod	1	1	1	1	1	1	1	1	1	1	1	1	1	1
31†	-----	SCREW, pan head #10-24 x 3/8	2	2	2	2	2	2	2	2	2	2	2	2	2	2
32	19C041	BRACKET, R3, iso-lube, painted	1	1	1	1	1	1	1	1	1	1	1	1	1	1
33◆	18C779	CAP, bottle, TSL	1	1	1	1	1	1	1	1	1	1	1	1	1	1
34◆	18E274	HOSE, polyethylene 1/4 od	7.5 feet (2.3 m)													
35	-----	PANEL, back, R3	1	1	1	1	1	1	1	1	1	1	1	1	1	1
36	132560PKG	GUARD, finger, 80 mm fan	1	1	1	1	1	1	1	1	1	1	1	1	1	1
37	-----	SCREW, SL hex head #10-24 x 1/2	16	16	16	16	16	16	16	16	16	16	16	16	16	16
38	-----	FLANGE NUT, 5/16-18	2	2	2	2	2	2	2	2	2	2	2	2	2	2
39	-----	SCREW, socket cap #6-32 x 7/8	4	4	4	4	4	4	4	4	4	4	4	4	4	4
40	18B272	HOSE, coupled, R3, fluid, -8 jic	2	2	2	2	2	2	2	2	2	2	2	2	2	2
41	117502	FITTING, reducer #5 x #8 (jic)	1	1	1	1	1	1	1	1	1	1	1	1	1	1
42	117677	FITTING, reducer #6 x #10 (jic)	1	1	1	1	1	1	1	1	1	1	1	1	1	1
43	-----	INSULATOR, foam, heater	2	2	2	2	2	2	2	4	4	4	4	4	4	4
44◆	18D006	FITTING, 1/8 in. npt, 1/16 in. npt	2	2	2	2	2	2	2	2	2	2	2	2	2	2
45†	-----	SCREW, FL hex head, 1/4-20 x 1/2	8	8	8	8	8	8	8	8	8	8	8	8	8	8
46	114225	TRIM, edge protection	1	1	1	1	1	1	1	1	1	1	1	1	1	1
47†	132478PKG	CABLE, thermistor			2				2			2				2
48†	-----	CABLE, gca, m/f, 1.2m	2	2	5	2	2	2	5	2	2	5	2	2	2	5
49†	132477PKG	CABLE, over-temp, heater, dual										1	1	1	1	1
	132476PKG	CABLE, over-temp, heater, single	1	1	1	1	1	1	1	1						
51	-----	INSULATOR, insolex, 0.75 id x 1.5 od	2	2	2	2	2	2	2	2	2	2	2	2	2	2
53	29A420	ARTWORK, identification	1	1	1	1	1	1	1	1	1	1	1	1	1	1
54	16U530	MODULE, sys srg prot	1	1	1	1	1	1	1	1	1	1	1	1	1	1
55	24U845	HOSE, pressure relief	2	2	2	2	2	2	2	2	2	2	2	2	2	2
56◆	25B521	FITTING, compression, adapt, 90, 1/4 in.	2	2	2	2	2	2	2	2	2	2	2	2	2	2
57	18E201	COVER, R3, lower-top, painted	1	1	1	1	1	1	1	1	1	1	1	1	1	1
58		COVER, R3, lower-bottom, painted	1	1	1	1	1	1	1	1	1	1	1	1	1	1
59	-----	SCREW, FL hex head, 1/4-20 x 3/8	4	4	4	4	4	4	4	4	4	4	4	4	4	4
60	-----	SCREW, socket cap 1/4-20 x 2-1/4	3	3	3	3	3	3	3	3	3	3	3	3	3	3
61	-----	GASKET, manifold	1	1	1	1	1	1	1	1	1	1	1	1	1	1
62†	-----	PLUG, 1/16-27 nptf	4	4	4	4	4	4	4	4	4	4	4	4	4	4
63◆	25B524	CLIP, t-clip, snap-in	2	2	2	2	2	2	2	2	2	2	2	2	2	2
64†	-----	BAR, 55 gal chem. meas. a side (see <b>Ship Loose Parts</b> on page 67)		1	1	1		1	1		1	1	1		1	1
65†	-----	BAR, 55 gal chem. meas. b side (see <b>Ship Loose Parts</b> on page 67)		1	1	1		1	1		1	1	1		1	1
66†	24U846	BRIDGE, plug-in jumper, ut35	4	4	4	4	4	4	4	4	4	4	4	4	4	4
67†	-----	CAP, 9/16-18 jic cap-aluminum	1	1	1	1	1	1	1	1	1	1	1	1	1	1
68†	-----	CAP, 1/2-20 jic cap-aluminum	1	1	1	1	1	1	1	1	1	1	1	1	1	1



Ref.	Part	Description	Qty.													
			26R310	26R311	26R312	26R313	26R320	26R321	26R322	26R330	26R331	26R332	26R333	26R340	26R341	26R342
69†	132482PKG	CABLE, reed switch	1	1	1	1	1	1	1	1	1	1	1	1	1	
70†	132518PKG	HARNESS, fan, transformer	1	1	1	1	1	1	1	1	1	1	1	1	1	
71†	133231PKG	CONNECTOR, plug, 7.62 mm, 4-position	1	1	1	1	1	1	1	1	1	1	1	1	1	
72†	132484PKG	CONNECTOR, plug, 3.81 mm (8 position)	1	1	1	1	1	1	1	1	1	1	1	1	1	
73†	132485PKG	CONNECTOR, plug, 10.16 mm (8 position)	1	1	1	1	1	1	1	1	1	1	1	1	1	
74†	-----	SUPPRESSOR, ferrite, dia. 400	1	1	1	1	1	1	1	1	1	1	1	1	1	
75†	-----	SUPPRESSOR, round snap ferrite .260	1	1	1	1	1	1	1	1	1	1	1	1	1	
76†	-----	LABEL, identification	1	1	1	1	1	1	1	1	1	1	1	1	1	
77†	-----	BRACKET, wall mount, left (see <b>Ship Loose Parts</b> on page 67)	1	1	1	1	1	1	1	1	1	1	1	1	1	
78†	-----	BRACKET, wall mount, right (see <b>Ship Loose Parts</b> on page 67)	1	1	1	1	1	1	1	1	1	1	1	1	1	
79▲	25T998	LABEL, safety	1	1	1	1	1	1	1	1	1	1	1	1	1	
80†	127553	FITTING, straight, 1/4t x 1/8 npt	1	1	1	1	1	1	1	1	1	1	1	1	1	
81◆	112738	GROMMET	2	2	2	2	2	2	2	2	2	2	2	2	2	
82†	-----	LABEL, self laminating	1	1	1	1	1	1	1	1	1	1	1	1	1	
83	29A382	ARTWORK, identification	1	1	1	1	1	1	1	1	1	1	1	1	1	
85†	-----	ENVELOPE, packing, self-adhesive	1	1	1	1	1	1	1	1	1	1	1	1	1	
86†	-----	LABEL, installation	1	1	1	1	1	1	1	1	1	1	1	1	1	
87†	-----	JACKET, scuff, R3, machine joint (see <b>Ship Loose Parts</b> on page 67)	1	1	1	1	1	1	1	1	1	1	1	1	1	
88†	17R703	CABLE, gca, m/f, 0.3m			2				2			2			2	
89†	25E540PKG	CONNECTOR, splitter			1				1			1			1	
90	29A376	ARTWORK, identification	1	1	1	1	1	1	1	1	1	1	1	1	1	
91†	-----	TIE, cable, 7.5 in.	1	1	1	1	1	1	1	1	1	1	1	1	1	
92	18D314PKG	SHIELD, membrane, ADM, 10-pack	1	1	1	1	1	1	1	1	1	1	1	1	1	
93	206994	FLUID, TSL, 8 oz bottle	1	1	1	1	1	1	1	1	1	1	1	1	1	
94◆	133416	STRAINER, suction, 1/4 npt	1	1	1	1	1	1	1	1	1	1	1	1	1	
95◆	16E254	FITTING, connector, male, straight	1	1	1	1	1	1	1	1	1	1	1	1	1	
96◆	102478	STRAP, tie wiring	1	1	1	1	1	1	1	1	1	1	1	1	1	
98	132001	BOLT, flange hd, serrated, 3/8	4	4	4	4	4	4	4	4	4	4	4	4	4	
101	-----	SCREW, button head, 1/4-20 x 3/4	3	3	3	3	3	3	3	3	3	3	3	3	3	
105	128036	SLEEVE, split, wire, 0.63 ID	1	1	1	1	1	1	1	1	1	1	1	1	1	
117	18E275	FITTING, elbow, swpt, 08 x 08, mf, cs	2	2	2	2	2	2	2	2	2	2	2	2	2	

† Not shown.

◆ Included in TSL system kit 18E273. Additional parts included in kit, see **Repair Kits** on page 68.

▲ Replacement safety labels, tags, and cards are available at no cost.

## Drivers Parts

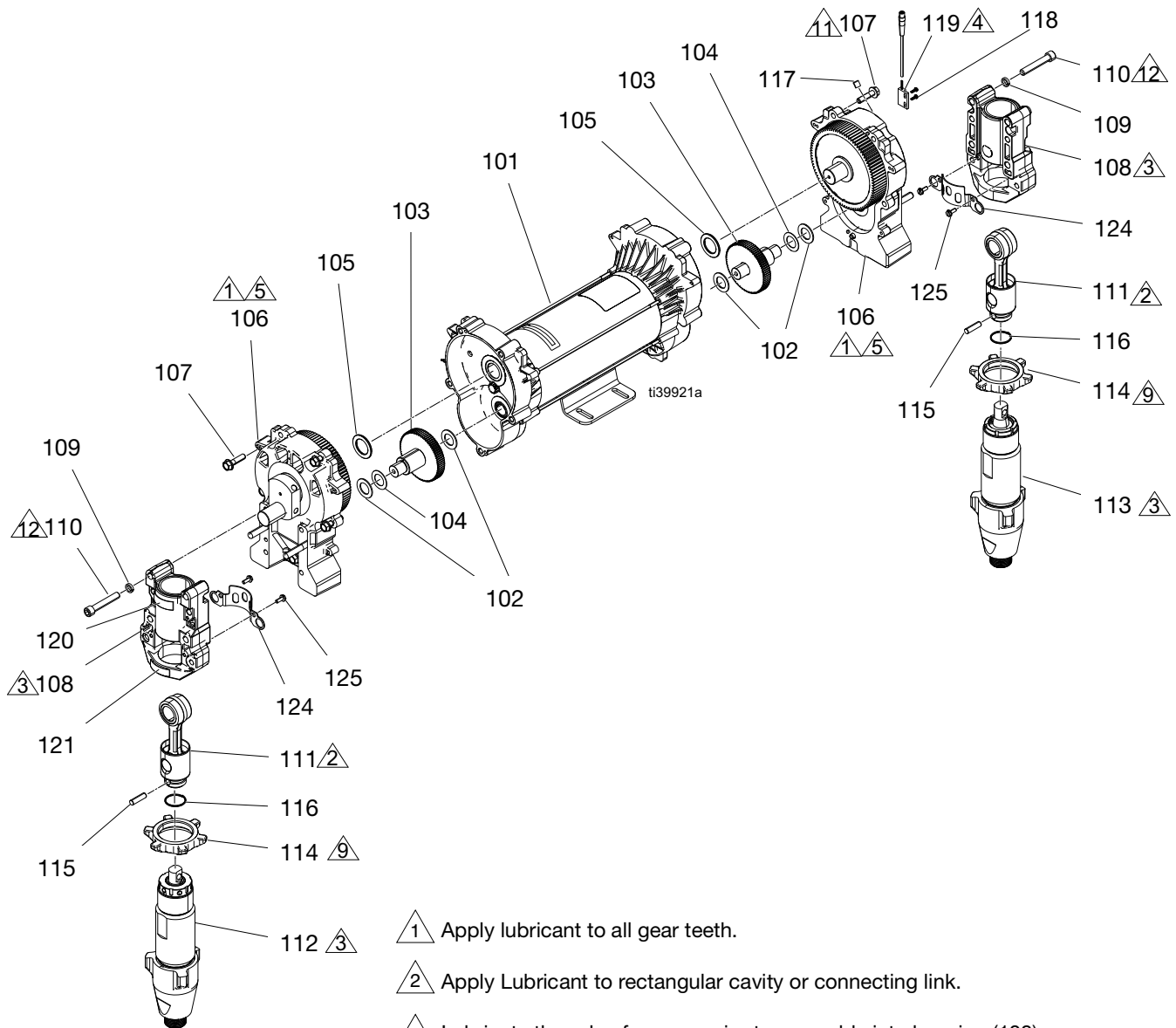

- 1 Apply lubricant to all gear teeth.
- 2 Apply Lubricant to rectangular cavity or connecting link.
- 3 Lubricate threads of pumps prior to assembly into housing (108).
- 4 Reed switch mounts to housing (106) with wire leads facing up.
- 5 Housing must be installed on motor with crankshafts aligned with each other.
- 9 Finger tighten on both sides.
- 11 Torque to 200 +/- 10 in-lb (22.5 +/- 1.1 N•m).
- 12 Torque to 25-30 ft-lb (33.8 - 40.6 N•m).

## Drivers Parts List

Ref.	Part	Description	Qty.		
			E-20/E-XP1	E-30	E-XP2
101	25R359	MOTOR, bldc, 2.5 hp, 2-end, 1-way		1	1
	25R357	MOTOR, bldc, 1.75hp, 2-end, 1-way	1		
102	-----	WASHER, thrust	4	4	4
103	-----	GEAR, combination,1595		2	2
	-----	GEAR, combination	2		
104	-----	WASHER, thrust	2	2	2
105	-----	WASHER, thrust, (1595)		2	2
	-----	WASHER, thrust, (1095/795)	2		
106	18E189	HOUSING, drive, E-20, R3	2		
	17W869	HOUSING, drive, R2, assembly		2	2
107	15C753	SCREW, FL hex head 5/16-18 x 1-1/4	10	10	10
108‡❖★†	257355	HOUSING, bearing			2
	20B456	HOUSING, bearing	2		
	245927	HOUSING, bearing		2	
109	-----	WASHER, lock (hi-collar)	8	8	8
110	114666	SCREW, cap, socket head		8	8
	17E788	SCREW, cap, sch, 3/8 x 1.5, sst	8		
111‡❖★†	241279	ROD, connecting		2	2
	287180	ROD, connecting	2		
112†	25P944	PUMP, displacement, tsl cir, .743		1	
	25P857	PUMP, displacement, tsl cir, .396	1		
	25P858	PUMP, displacement, tsl cir, .552			1
113‡	18D010	PUMP, displacement(.396/255.79)	1		
	245971	PUMP, displacement (.552/356.26)			1
	245972	PUMP, displacement (.743/479.22)		1	
114‡❖★†	262675	NUT, retaining			2
	17A257	NUT, jam, pump	2		
	193394	NUT, retaining		2	
115‡❖★†	176818	PIN, str, hdls	2		
	183210	PIN, str, hdls		2	2
116★†	183169	SPRING, retaining		2	2
117	116618	MAGNET	1	1	1
118*	-----	SCREW, hxhd, thd cut, 4-40 x .375	2	2	2
119*	25R301PKG	SWITCH, reed, assembly	1	1	1
120❖★†‡	187436	LABEL, torque	2		
	187437	LABEL, torque		2	2
121▲★†‡❖	192840	LABEL, safety, warning, pinch	2	2	2
122✖	-----	LUBRICANT, grease	1	1	1
123✖	-----	LUBRICANT, grease, ep	1	1	1
124★‡	15C762	SHIELD, pump rod		2	2
125★‡†❖	118444	SCREW, SL hex head #10-24 x 1/2		4	4

✖ Not shown.

▲ Replacement safety labels, tags, and cards are available at no cost.

❖ Included in A-side repair kits 18E197 (for E-20 and EXP1).

† Included in A-side repair kits 18E193 (for E-XP2), and 18E199 (for E-30).

‡ Included in B-side repair kits 18E198 (for E-20 and E-XP1).

★ Included in A-side repair kits 18E194 (for E-XP2) and 18E200 (for E-30).

\* Included in repair kit 18E138.

# Heaters

## 18E141, 18E142, 18E145, and 18E146 Parts

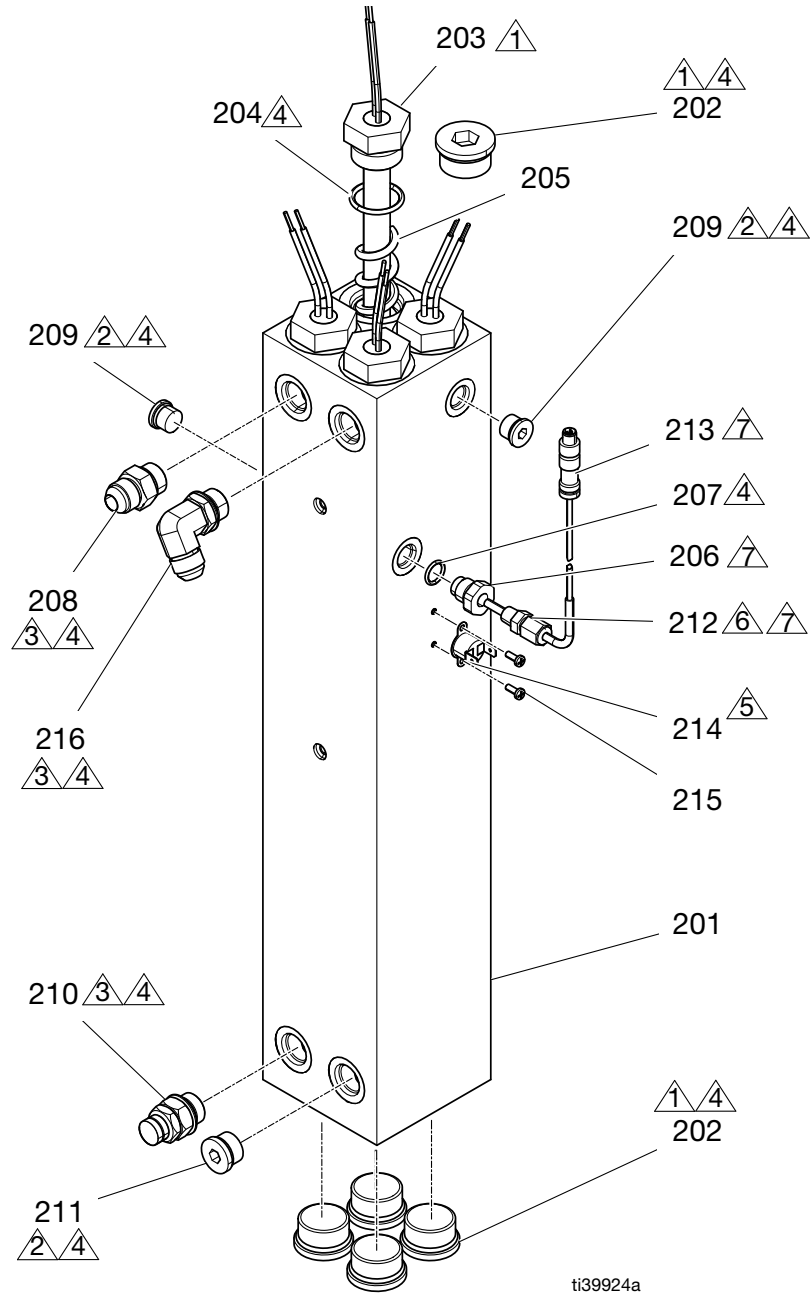

1 Torque to 120 ft-lb (162.3 N•m).

2 Torque to 23 ft-lb (31.2 N•m).

3 Torque to 40 ft-lb (54.2 N•m).

4 Apply lubricant to o-rings before assembling.

5 Apply thermal paste to base of switch.

6 Apply sealant and tape to all non-swiveling and non-drying threads.

7 Assemble compression fitting into adapter and tighten to 17 ft-lb (23 N•m). Insert sensor into compression fitting, then tighten compression nut to 21 +/- 2 ft-lb (28 +/- 2.7 N•m). While holding the sensor against the heater rod. Hold the npt portion of the compression fitting while tightening to prevent rotation of the fitting body.

### 18E141, 18E142, 18E145, and 18E146 Parts List

Ref.	Part	Description	Qty.			
			18E141	18E142	18E145	18E146
201	-----	BLOCK, heater, machined, R3, dual	1	1		
	-----	BLOCK, heater, machined, r3, single			1	1
202	15H305	FITTING, plug hollow hex 1-3/16 sae	4	4	5	5
203a	-----	HEATER, immersion, 2400W, 230V	4	2	3	3
203b‡	-----	HEATER, immersion, 1380W, 230V		2		
204	124132	O-RING	4	4	3	3
205	-----	SPRING, mixer, heater	4	4	3	3
206	-----	ADAPTER, thermocouple, 9/16 x 1/8	2	2	1	1
207	120336	O-RING, packing	2	2	1	1
208	121309	FITTING, adapter, sae-orb x jic	2	2	1	1
209	15H304	FITTING, plug 9/16 sae			2	2
210	247520	HOUSING, rupture disc	2	2	1	1
211	295607	PLUG, hex	2	2	1	1
212	123325	FITTING, compression, 1/8 npt, ss	2	2	1	1
213	24L973	SENSOR, rtd, 1kohm, 90deg, 4 pin, tip	2	2	1	1
214	15B137	SWITCH, over temperature	1	1	1	1
215	124131	SCREW, mach, pnh	2	2	2	2
216	121312	FITTING, elbow, sae x jic	2	2	1	1
218✖	-----	LUBRICANT, temporary assembly	1	1	1	1
219✖	-----	SEALANT, pipe, sst	1	1	1	1
220✖	-----	LUBRICANT, thermal	1	1	1	1

✖ Not shown.

‡ See schematic for heater rod placement.

# Manifolds

## 18E207 Parts

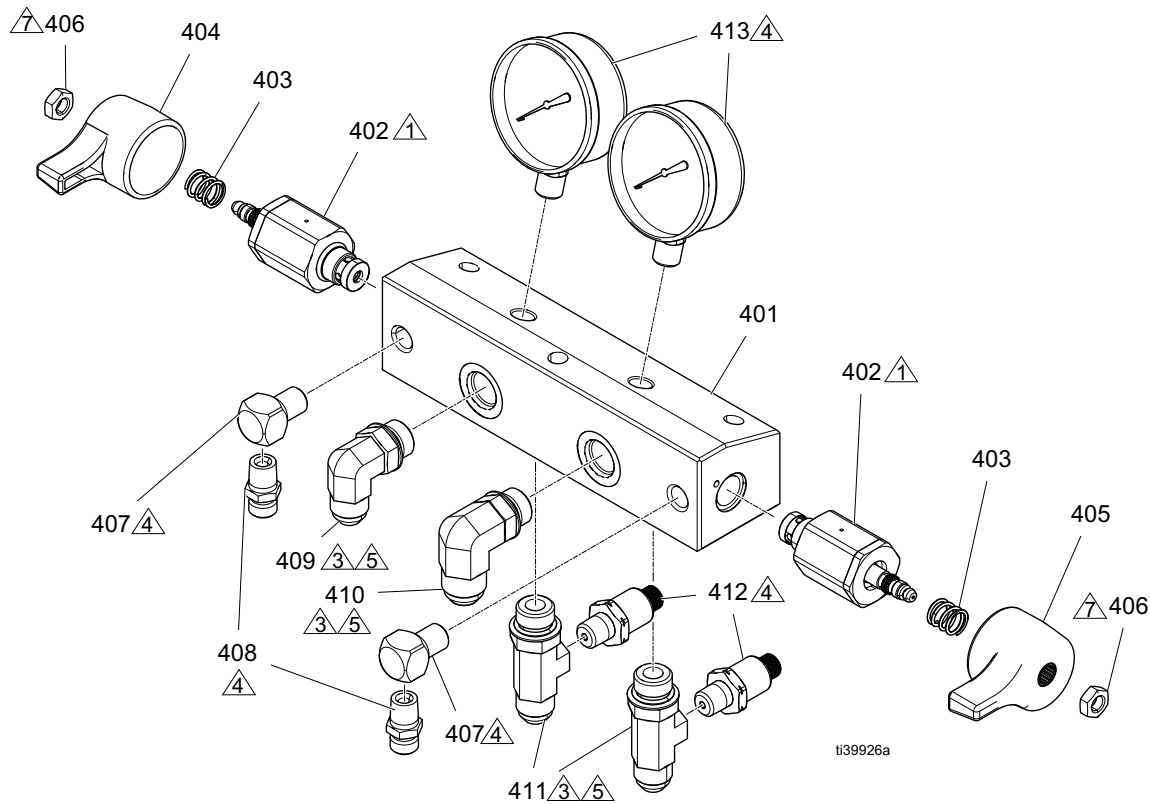

- 1 Apply sealant to threads and torque to 372 +/- 24 in-lb (42 +/- 2.7 N•m).
- 2 Verify installation of o-ring before installing the fitting.
- 3 Apply lubricant to o-rings before assembly.
- 4 Apply tape and sealant to all non-swiveling pipe threads.
- 5 Apply sealant to threads.

## 19C283 Parts List

Ref.	Part	Description	Qty.
401	-----	HOUSING, outlet	1
402††★	247824	VALVE, drain valve	2
403††★	150829	SPRING, compression	2
404††	15J915	HANDLE, red	1
405†★	15J916	HANDLE, blue	1
406††★	112309	NUT, hex, jam	2
407	100840	FITTING, elbow, street	2
408	162453	FITTING, (1/4 npsm x 1/4 npt)	2
409	-----	FITTING, elbow, jic-8 x orb-8	1
410	-----	FITTING, elbow, jic-10 x orb-8	1
411	-----	FITTING, tee, orb-8, jic-8, 1/4-npt	2

Ref.	Part	Description	Qty.
412	18B074PKG	TRANSDUCER, pressure, 5000 psi	2
413	102814	GAUGE, press, fluid	2
414✘	-----	LUBRICANT, grease	1
415✘	070274	TAPE, tfe, sealant	1
416✘	-----	SEALANT, pipe, sst	1
417✘	-----	SEALANT, anaerobic, blue	1

- ✘ Not shown.
- † Included in drain valve set kit 255148.
- ‡ Part included in ISO drain valve kit 255149.
- ★ Included in RESIN drain valve kit 255150.

18E208 Parts

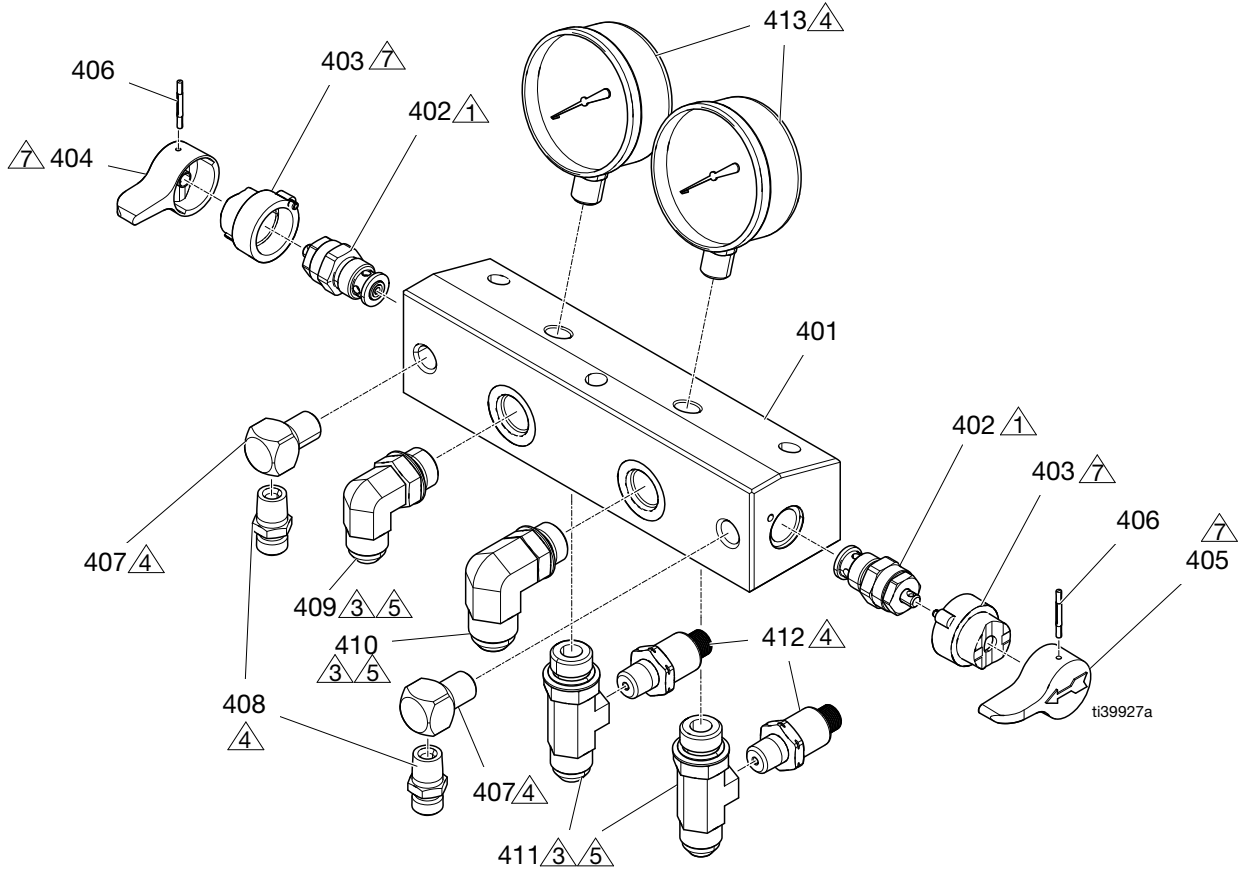

- 1 Apply sealant to threads and torque to 250 +/- 10 in-lb (28 +/- 1.1 N•m).
- 2 Verify installation of o-ring before installing the fitting.
- 3 Apply lubricant to o-rings before assembly.
- 4 Apply tape and sealant to all non-swiveling pipe threads.
- 5
- 6 Apply lubricant to mating surfaces.
- 7

25R471 Parts List

Ref.	Part	Description	Qty.
401	-----	HOUSING, outlet	1
402	239914	VALVE, drain	2
403	224807	BASE, valve	2
404	17X499	HANDLE, valve, drain, red	1
405	17X521	HANDLE, valve, drain, blue	1
406	111600	PIN, grooved	2
407	100840	FITTING, elbow, street	2
408	162453	FITTING, (1/4 npsm x 1/4 npt)	2
409	-----	FITTING, elbow, jic-8 x orb-8	1

Ref.	Part	Description	Qty.
410	-----	FITTING, elbow, jic-10 x orb-8	1
411	-----	FITTING, tee, orb-8, jic-8, 1/4-npt	2
412	18B074PKG	TRANSDUCER, pressure, 5000 psi	2
413	102814	GAUGE, press, fluid	2
414✘	-----	LUBRICANT, grease	1
415✘	070274	TAPE, tfe, sealant	1
416✘	-----	SEALANT, pipe, sst	1
417✘	-----	SEALANT, anaerobic, blue	1

✘ Not shown.

# Electrical Enclosures Parts

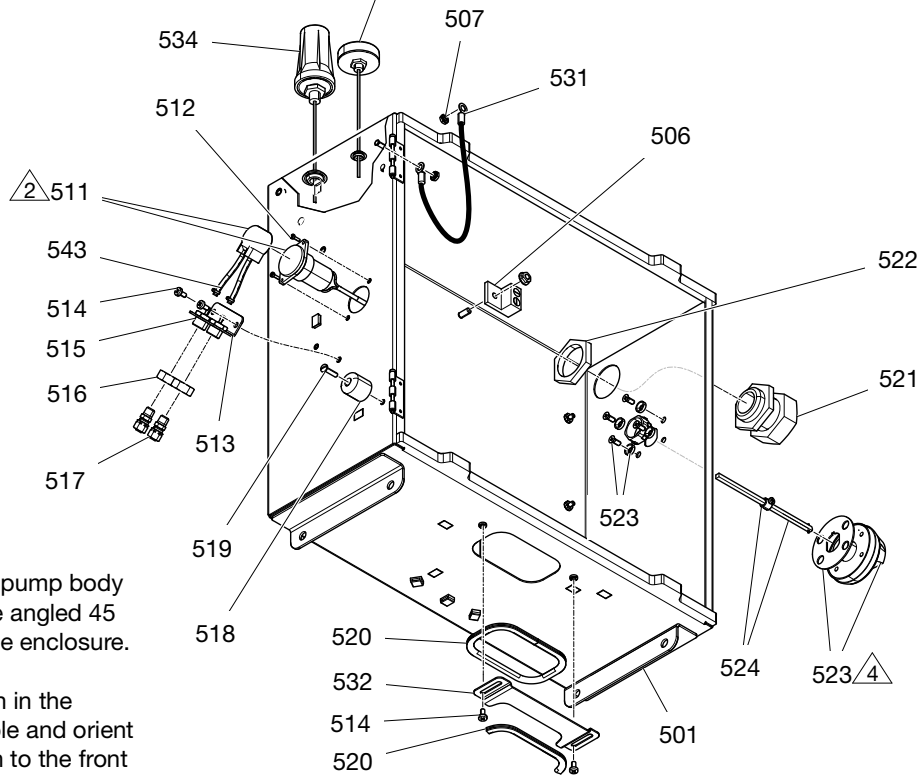
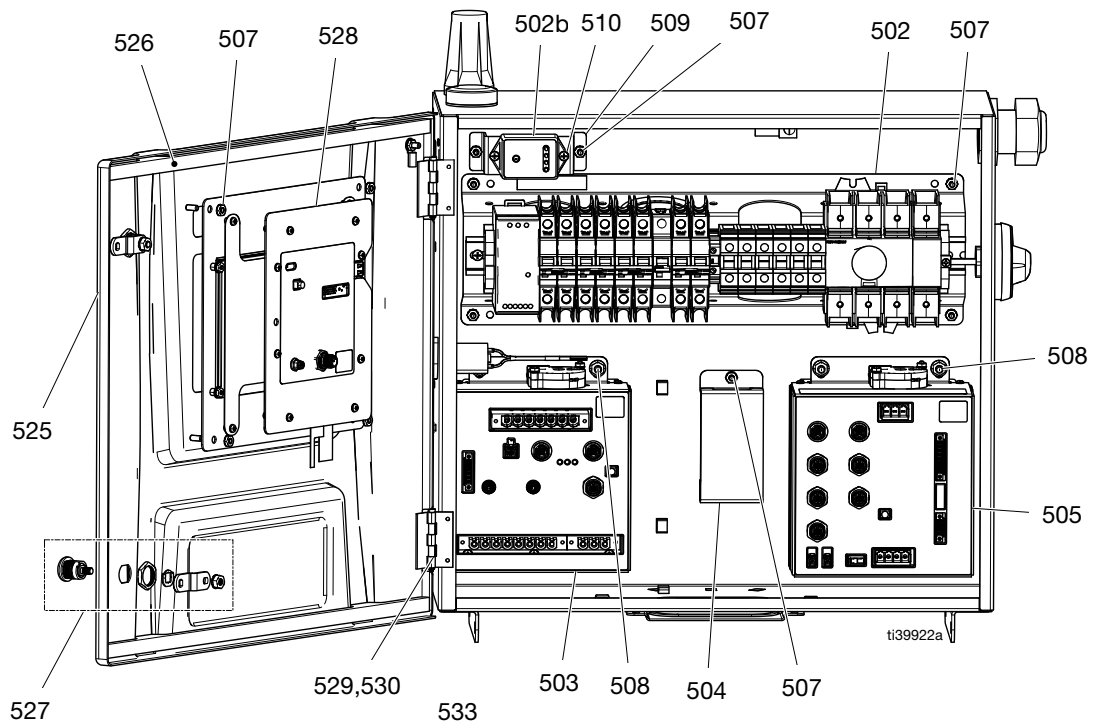

2 Assemble pump head to pump body so the outlet and inlet are angled 45 degrees to the back of the enclosure.

4 Orient shaft with shaft pin in the vertical position. Assemble and orient knob with the off position to the front of the enclosure.



## Electrical Enclosures Parts List

Ref.	Part	Description	Qty.	
			No Cell Module	Cell Module
501	-----	ENCLOSURE, weldment, R3, painted	1	1
502	-----	MODULE, din rail, see <b>Rail Module Parts</b> on page 64	1	1
503	25P036	MODULE, gca, tcm	1	1
504	-----	LABEL, installation	1	1
505	18B011	MODULE, gca, mcm2	1	1
506	117666	TERMINAL, ground	1	1
507	113505	NUT, keps, #10-24	14	14
508	115942	NUT, flanged, 1/4-20	5	5
509	-----	BRACKET, mov	1	1
510	114331	SCREW, phlw #6-32 x 3/8	2	2
511◆	18E137	PUMP, peristaltic, 24v, 3mm id	1	1
512◆	107388	SCREW, ph #4-40 x 3/8	2	2
513	18E276	BRACKET, iso fittings, painted	1	1
514	110637	SCREW, ph #10-24 x 3/8	4	4
515◆	18C769	FITTING, barb to 1/8 nptf	2	2
516◆	100155	NUT, hex, jam, 5/8	2	2
517◆	127553	FITTING, straight, 1/4t x 1/8 npt	2	2
518	-----	BUMPER, enclosure door, R3	2	2
519	-----	SCREW, ph #10-24 x 3/4	2	2
520	114225	TRIM, edge protection	1.6 ft	1.6 ft
521	120858	BUSHING, strain relief, M40 thread	1	1
522	120859	NUT, strain relief, M40 thread	1	1
523	18B671	KNOB, door interlocked	1	1
524	18B672	SHAFT, door interlocked	1	1
525	-----	DOOR, stamped, R3, painted	1	1
526	-----	FOAM, enclosure, R3	2	2
527	-----	LATCH, door	2	2
528	18E139	MODULE, GCA, ADM2, 9 in.	1	1
529	-----	PIN, weld hinge	2	2
530	-----	RING, retaining, e ring, 9/64	2	2
531	194337	WIRE, grounding, door	1	1
532	-----	PLATE, enclosure guard	1	1
533	132949PKG	ANTENNA, gps		1
534	132948PKG	ANTENNA, cellular		1
535✘	18D084	CABLE, can, female/female 0.9 m	1	1
536✘	-----	CABLE, can, female/female 0.6 m	1	1
537✘	18E184	ELECTRICAL CONNECTORS	1	1
538✘			1	1
539✘			1	1
540✘			1	1
541✘	-----	PLUG, 7/16 in. hole, ldpe, black	1	
542✘	-----	PLUG, 5/8 in. hole, rubber, black	1	
543◆	102478	STRAP, tie, wiring	2	2
544✘	18D295	CABLE, 4 pin, male / 90 deg fem 1.0 m		1

✘ Not shown.

◆ Included in TSL system kit 18E273. Additional parts included in kit, see **Repair Kits** on page 68.

# Inlet Strainers Parts

## 18E247 and 18E246 Parts

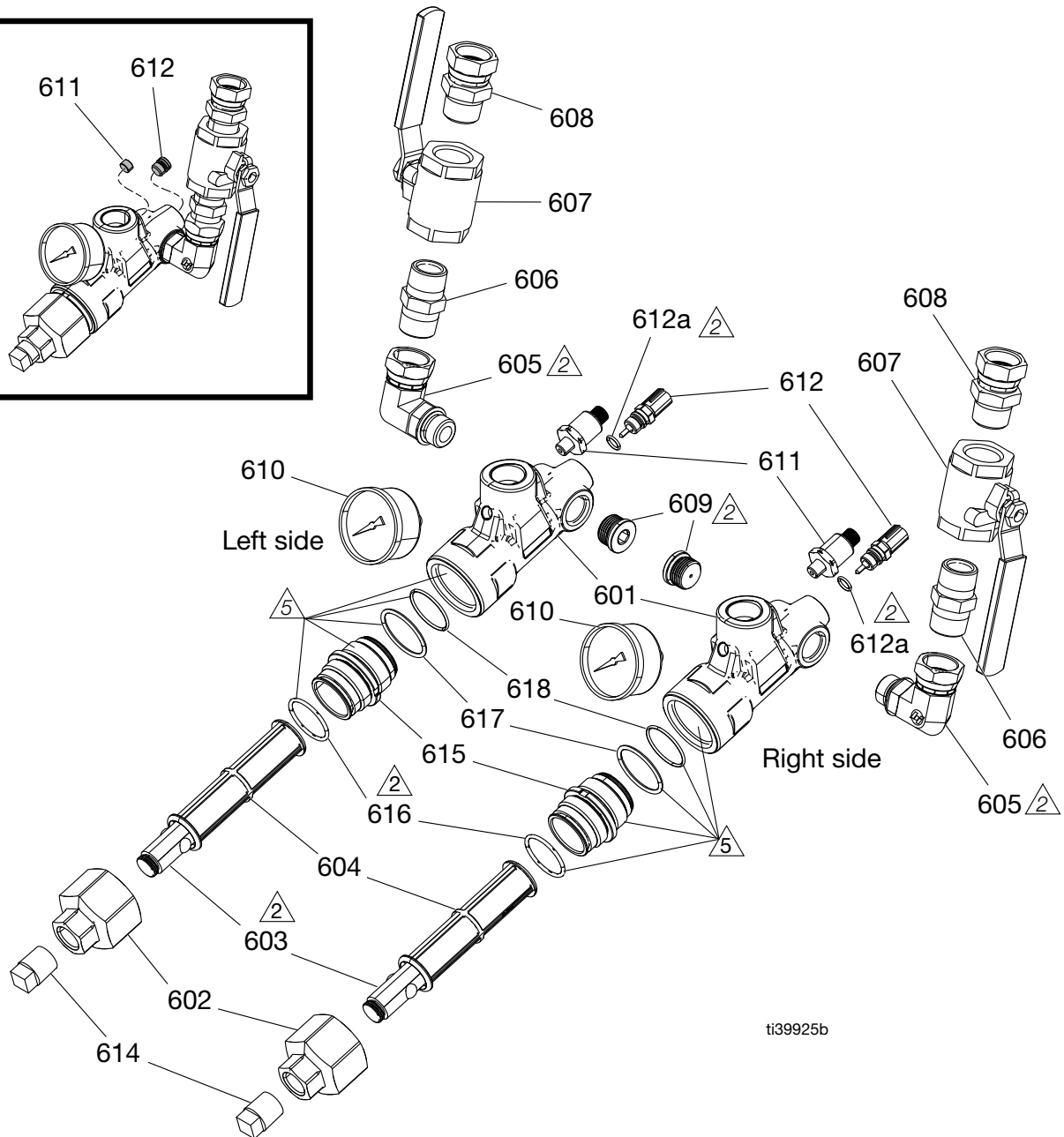
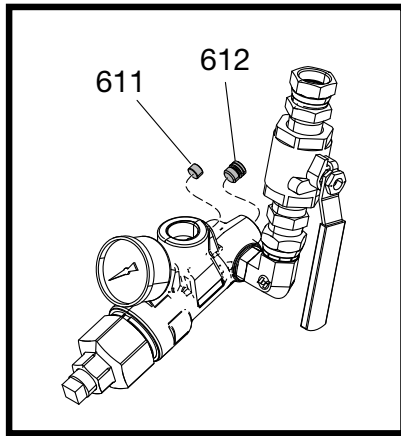

ti39925b

- △1 Apply sealant to all non-swivel pipe threads.
- △2 Apply lubricant to o-rings.
- △5 Apply adhesive to mating surfaces. Do not apply adhesive to inside bores of insert (615) or housing (601).

## 18E247 and 18E246 Parts List

Ref.	Part	Description	Qty.	
			18E247	18E246
601	18D179	STRAINER, housing, R3, machined	2	2
602	18E271	CAP, strainer, R3	2	2
603	15E288	INSERT, manifold	2	2
604*‡	132675	FILTER, fluid, 30 mesh	2	2
605	-----	FITTING, elbow, orb-10 x 3/4 npsm	2	2
606	119992	FITTING, pipe, nipple, 3/4 x 3/4 npt	2	2
607	109077	VALVE, ball 3/4 npt	2	2
608	118459	FITTING, union, swivel, 3/4 in.	2	2
609	556424	PLUG, pipe stl rd 7/8-14 sae mg	2	2
610	18E272	GAUGE, pressure, 500 psi	2	2
611	18B075PKG	TRANSDUCER, pressure, 1000 psi	2	
	104765	PLUG, pipe, headless, 1/8-27		2
612	20B457	SENSOR, temperature	2	
	18D158	PLUG, temp sensor		2
612a	106555	PACKING, o-ring	2	2
614	100737	PLUG, pipe	2	2
615	133171	INSERT, thread, cap, strainer, R3	2	2
616*‡	132444	O-RING, 125, fx75	2	2
617	107067	PACKING, o-ring	2	2
618	C24035	PACKING, o-ring	2	2
619*	-----	SEALANT, pipe, sst	1	1
620*	-----	LUBRICANT, grease	1	1
621*	-----	ADHESIVE, epoxy, gray	1	1

\* Not shown.

\* Included in 18E252 Inlet Strainer Filter Kit (2-pack) and 18E253 Inlet Strainer Filter Kit (10-pack).

\* Included in 18E151 Filter Cap O-ring Kit (10-pack).

‡ Included in 18E254 O-ring and Filter Kit (single).

# Rail Module Parts

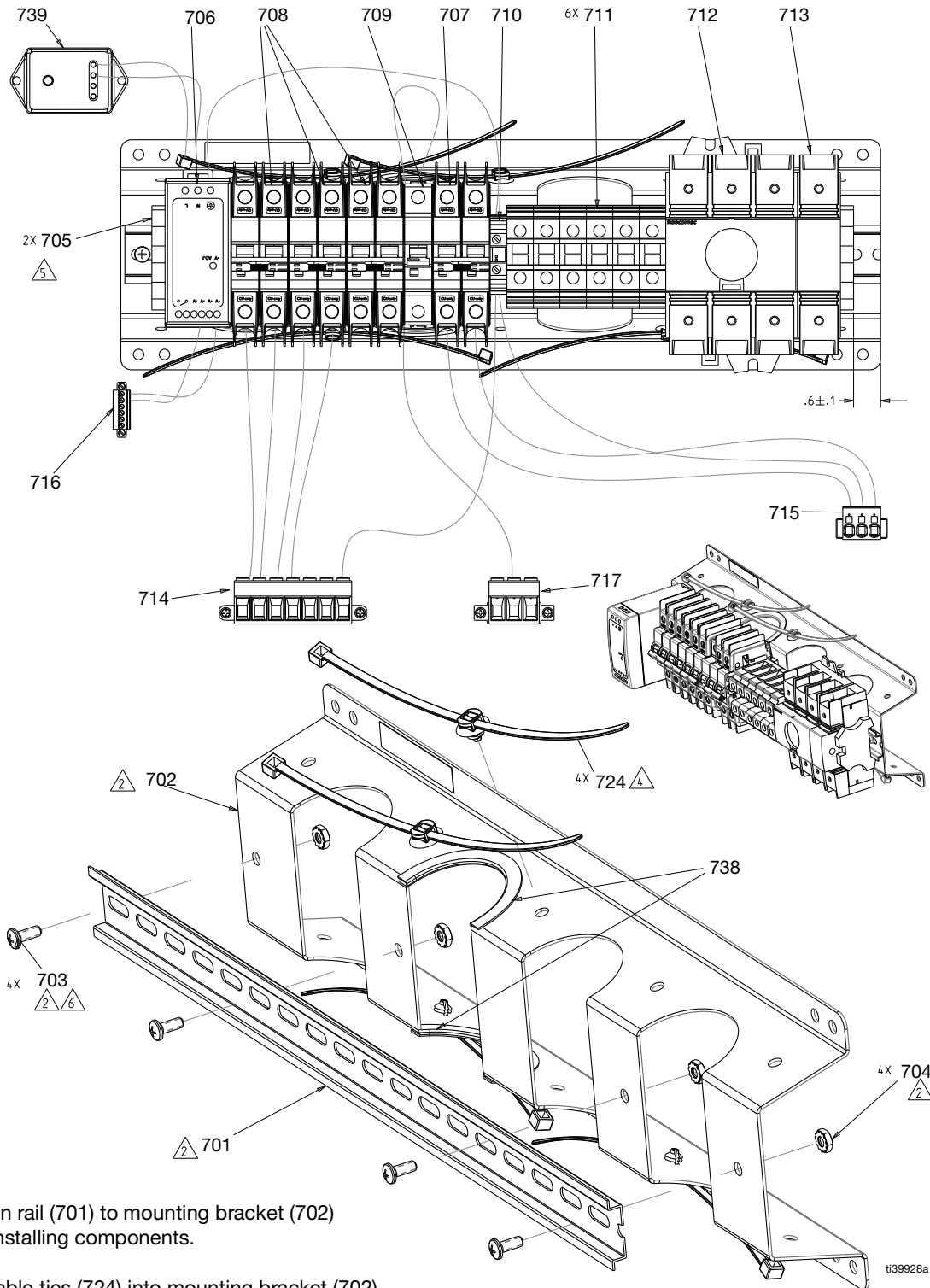

ti39928a

- 2 Install din rail (701) to mounting bracket (702) before installing components.
- 4 Install cable ties (724) into mounting bracket (702).
- 5 Torque to 14 in-lb (1.5 N•m).
- 6 Torque to 45 in-lb (5.2 N•m).

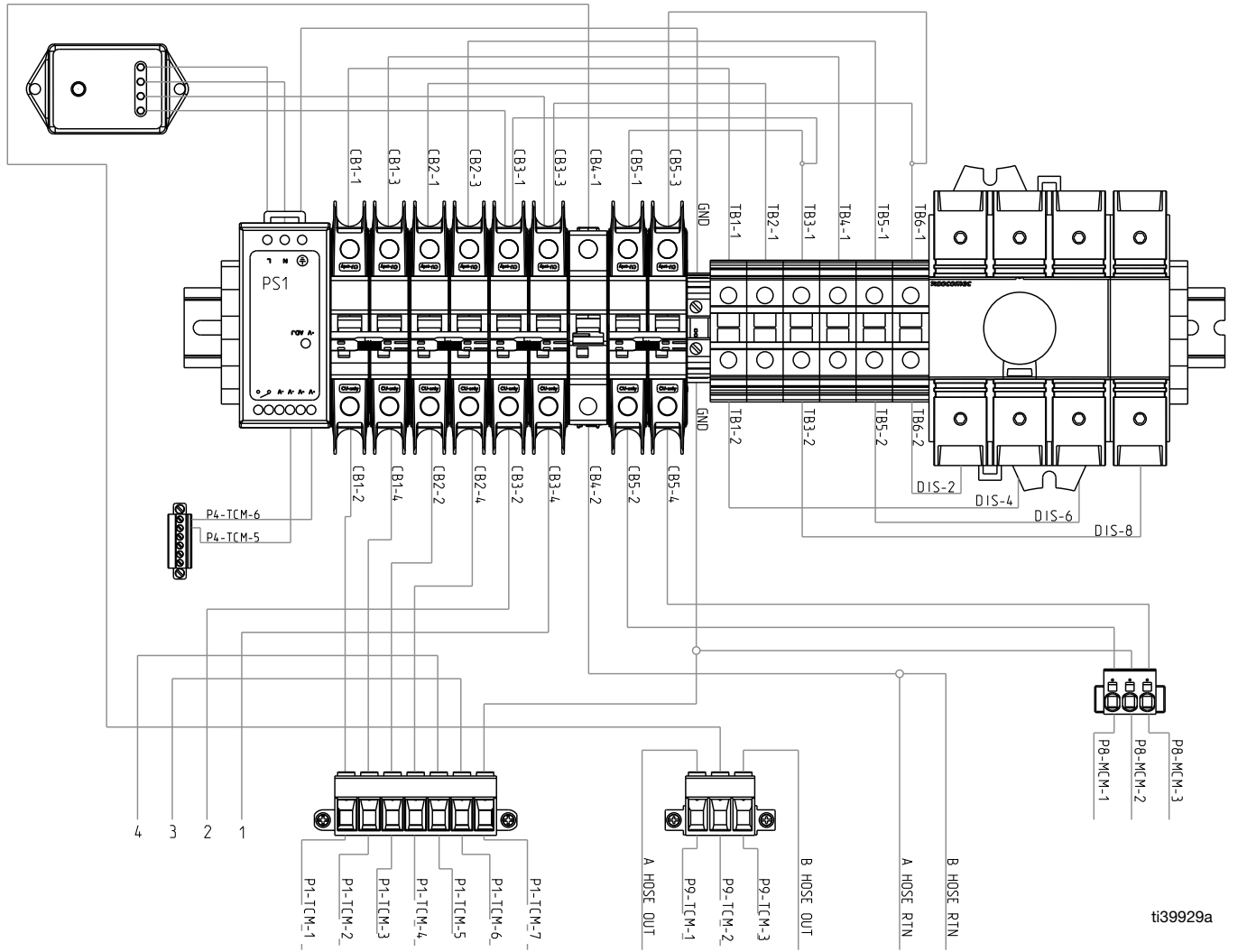

ti39929a

## Rail Module Parts List

Ref.	Part	Description	Qty.
701	-----	RAIL, mount, 18mm slot	1
702	-----	BRACKET, din rail	1
703	116610	SCREW, mach, phil, pan, #10	4
704	113505	NUT, keps, hex hd	4
705	120838	BLOCK, clamp end	2
706	126453	POWER SUPPLY, 24V	1
707	17A314	CIRCUIT, breaker, 2p, 20a, ul489, ab	1
708	17A317	CIRCUIT, breaker, 2p, 40a, ul489, ab	3
709	17A319	CIRCUIT, breaker, 1p, 50a, ul1077, ab	1
710	132931	BLOCK, ground, terminal	1
711	24R724	BLOCK, terminal, ut35	6
712	132801	SWITCH, rotary disconnect, 3p, 100a	1
713	132802	SWITCH, fourth pole, 100a, ul98	1
714	133472PKG	7-PIN connector, TCM	1
715	133471PKG	3-PIN connector, MCM	1
716	133470PKG	6-PIN connector, TCM	1
717	133469PKG	3-PIN connector, TCM	1
724	125625	TIE, cable, fir tree	4
725✘	-----	SLEEVE, split, wire, 1.00 id	1
729✘	128036	SLEEVE, split, wire, 0.63 id	1
736✘	-----	CONTACT, connector, pin, size 8	2
737✘	-----	CONTACT, connector, socket, size 8	2
738	114225	TRIM, edge protection	1
739	16U530	MODULE, sys srg prot	1

✘ Not shown.

# Ship Loose Parts

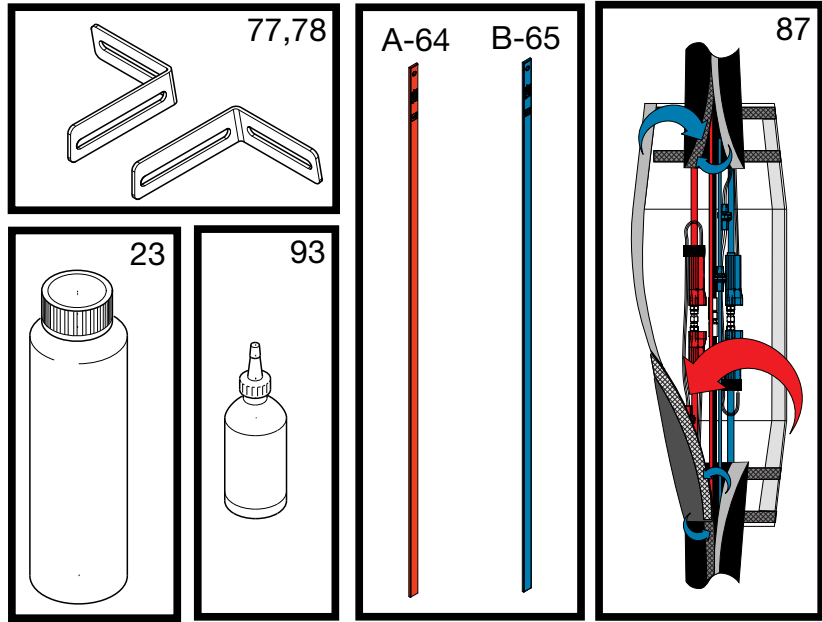

ti41038a

Ref.	Part	Description	Qty.
23	25T859	FLUID, TSL, 32 oz bottle	2
64+	24M174	BAR, 55 gallon chemical measure, A side	1
65+		BAR, 55 gallon chemical measure, B side	1
77	18E266	BRACKET, wall mount, left	1
78		BRACKET, wall mount, left	1
87	18D240PKG	JACKET, scuff, R3, machine joint	1
93	206994	FLUID, TSL, 8 oz bottle	1

+ Pro and Elite systems only.

## Repair Kits

### TSL System Kit (18E273)

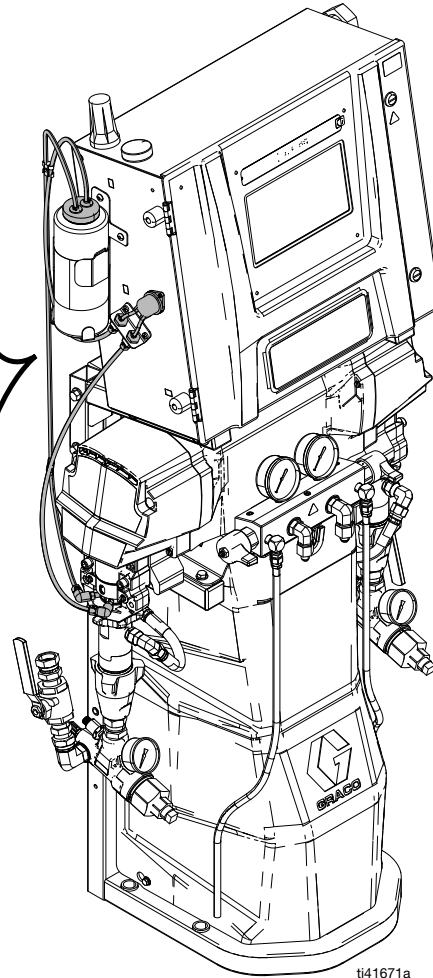
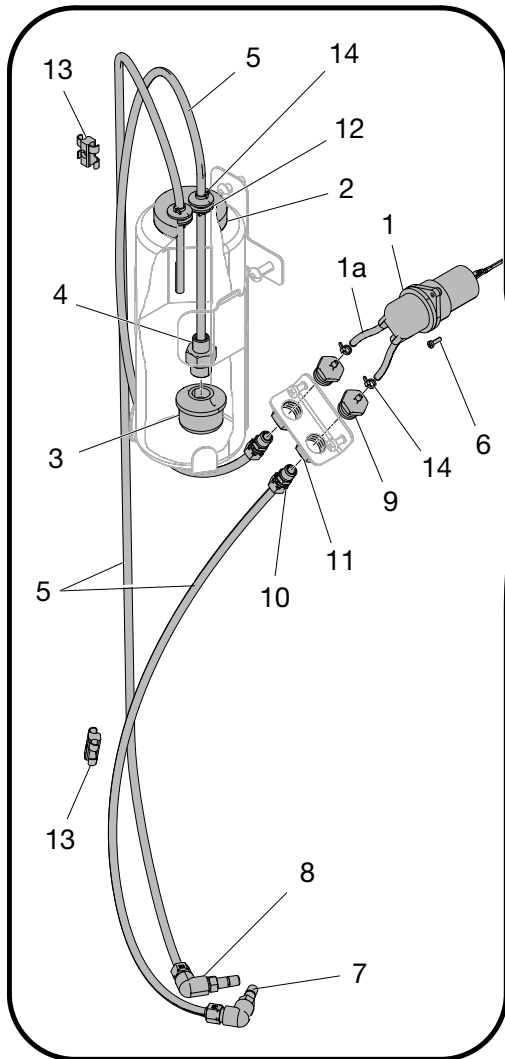

Ref.	Part	Description	Qty.
1*	18B274	PUMP, peristaltic, 24V, 3mm ID	1
1a	18D008	TUBE, repair kit, R3 TSL pump	1
2	18C779	CAP, bottle, TSL	1
3	133416	STRAINER, suction, 1/4 npt	1
4	16E254	FITTING, connector, male, straight	1
5	18E274	KIT, R3, TSL tubing, 7.5 ft	1
6*	107388	SCREW, mach, pnh	2
7	18D006	FITTING, 1/8 in. npt, 1/16 in. npt	2
8	25B521	FITTING, compression, adapter, 90, 1/4 in.	2
9	18C769	FITTING, BARN to 1/8 nptf	2

Ref.	Part	Description	Qty.
10	127553	FITTING, straight, 1/4 x 1/8 npt	2
11	100155	NUT, hex jam, 5/8 in.	2
12	112738	GROMMET	2
13	25B524	CLIP, T-clip, snap-in	2
14*	102478	STRAP, tie, wiring	6

\* Included in 18E137 TSL Pump Repair Kit.

#### Additional Kits:

18E265 - KIT, R3, TSL, bottle bracket  
 18E276 - KIT, R3, bracket, TSL fittings



# Electrical Schematics

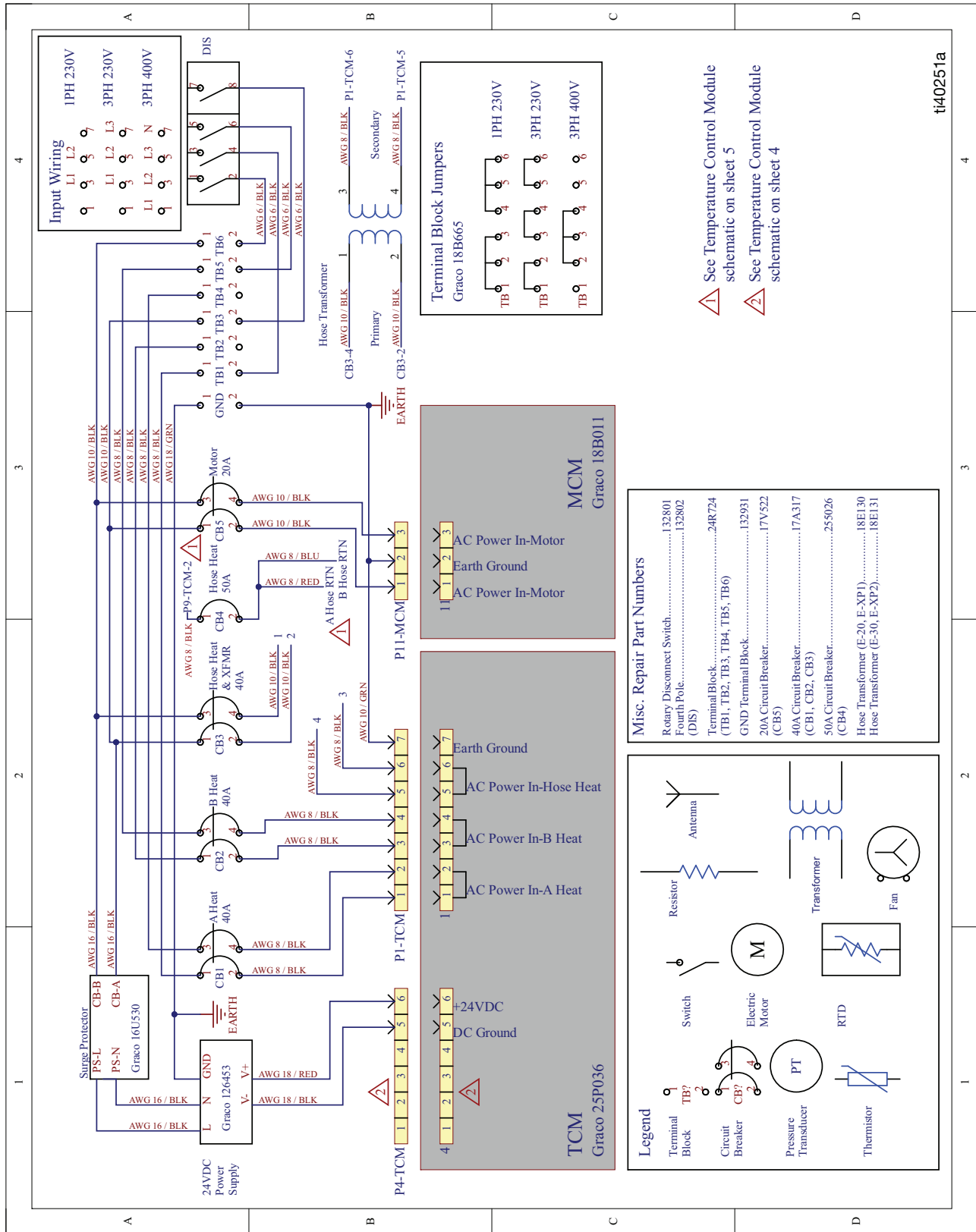

**Misc. Repair Part Numbers**

Rotary Disconnect Switch.....	132801
Fourth Pole.....	132802 (DIS)
Terminal Block.....	24R724 (TB1, TB2, TB3, TB4, TB5, TB6)
GND Terminal Block.....	132931 (CB5)
20A Circuit Breaker.....	17V522 (CB5)
40A Circuit Breaker.....	17A317 (CB1, CB2, CB3)
50A Circuit Breaker.....	255026 (CB4)
Hose Transformer (E-20, E-XP1).....	18E130
Hose Transformer (E-30, E-XP2).....	18E131

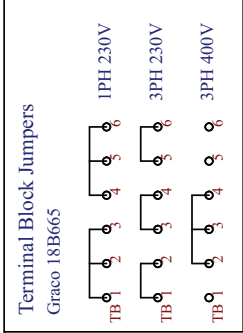
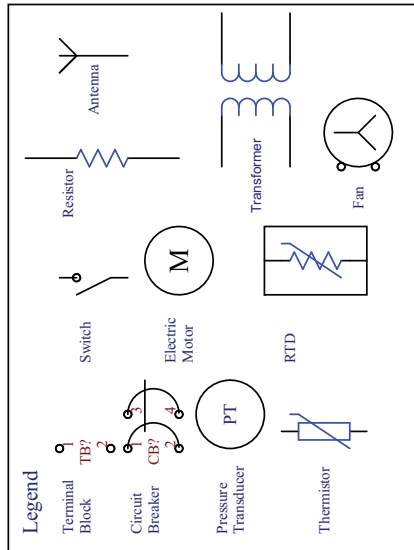

⚠ See Temperature Control Module schematic on sheet 5  
⚠ See Temperature Control Module schematic on sheet 4

t40251a



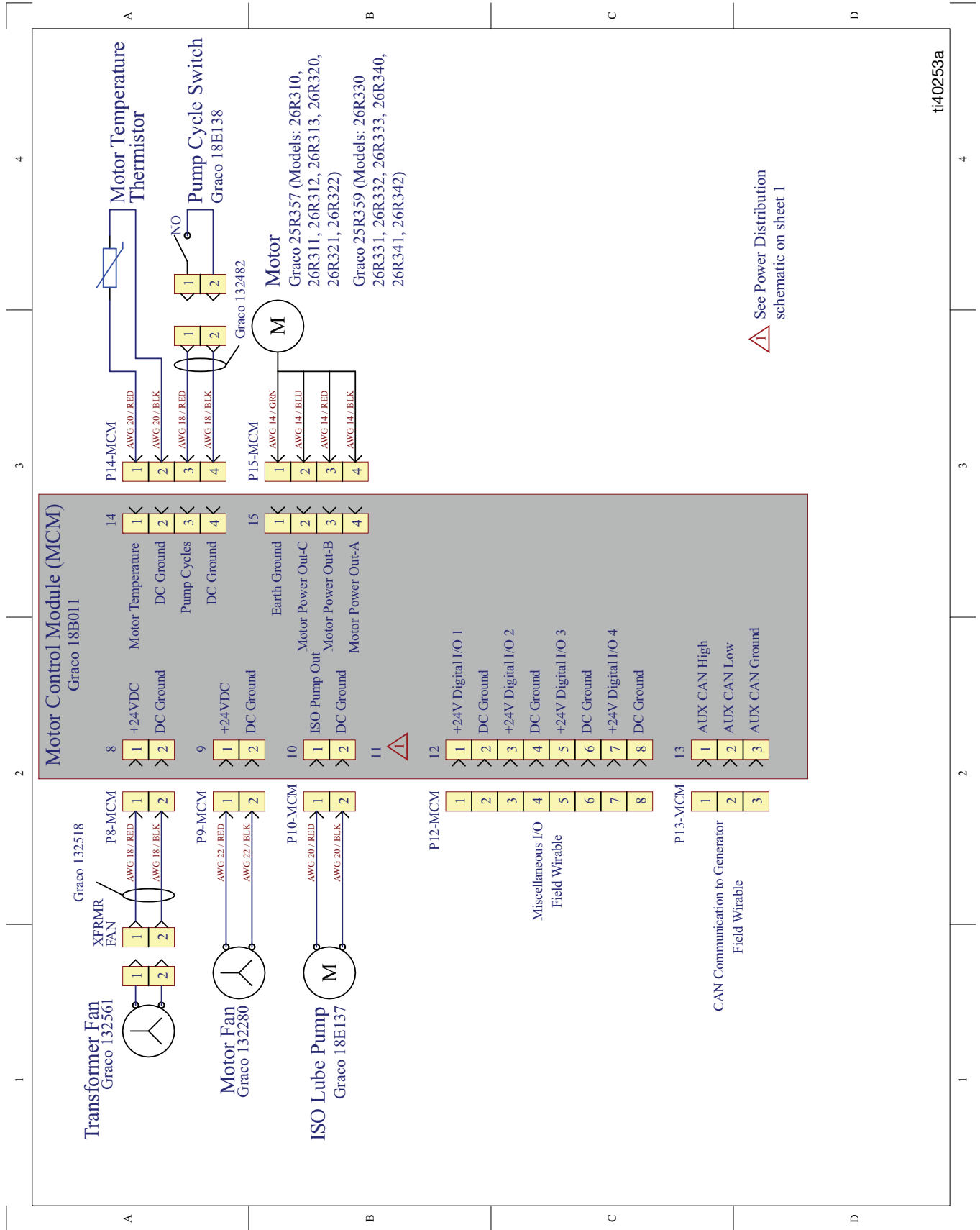

ti40253a

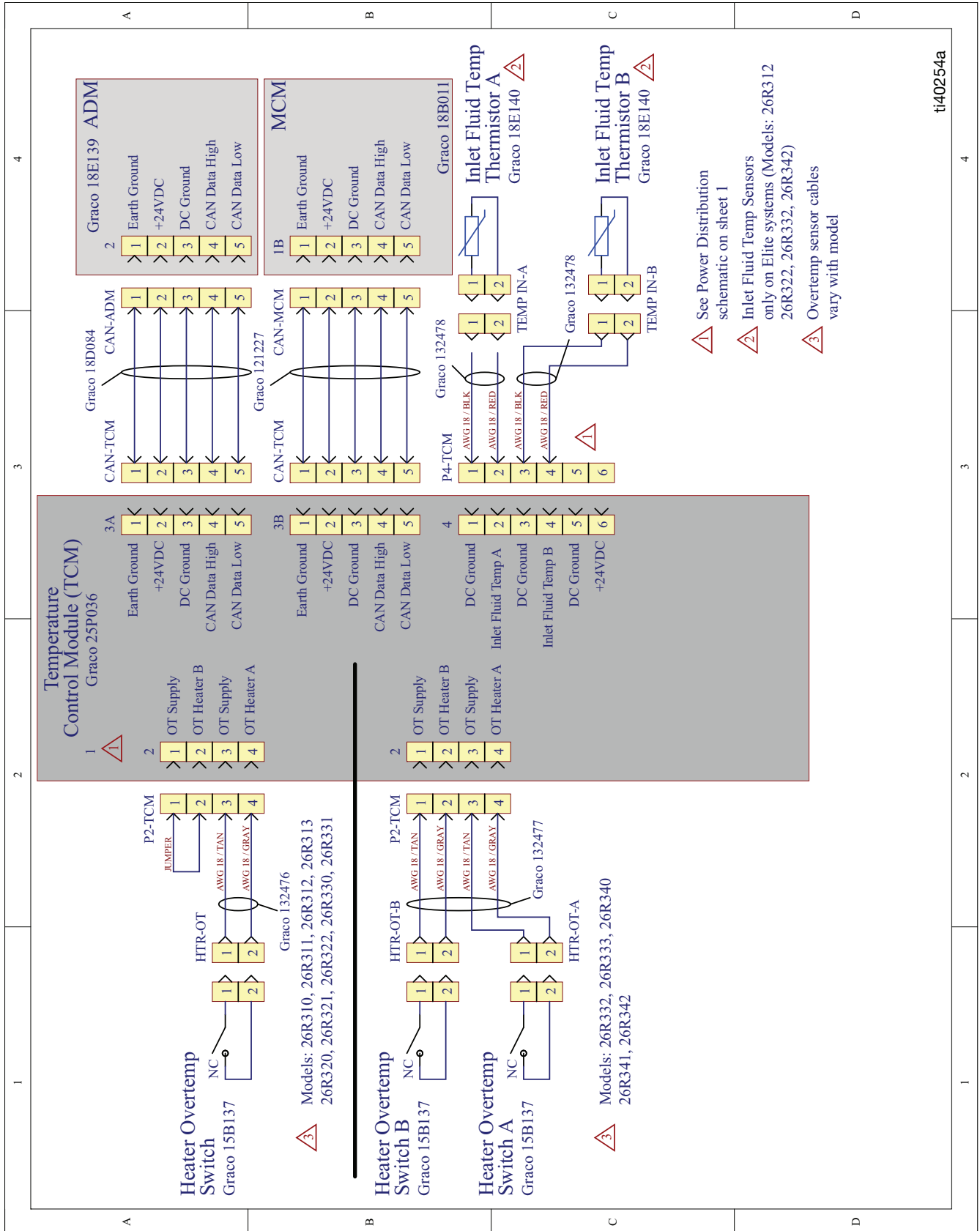

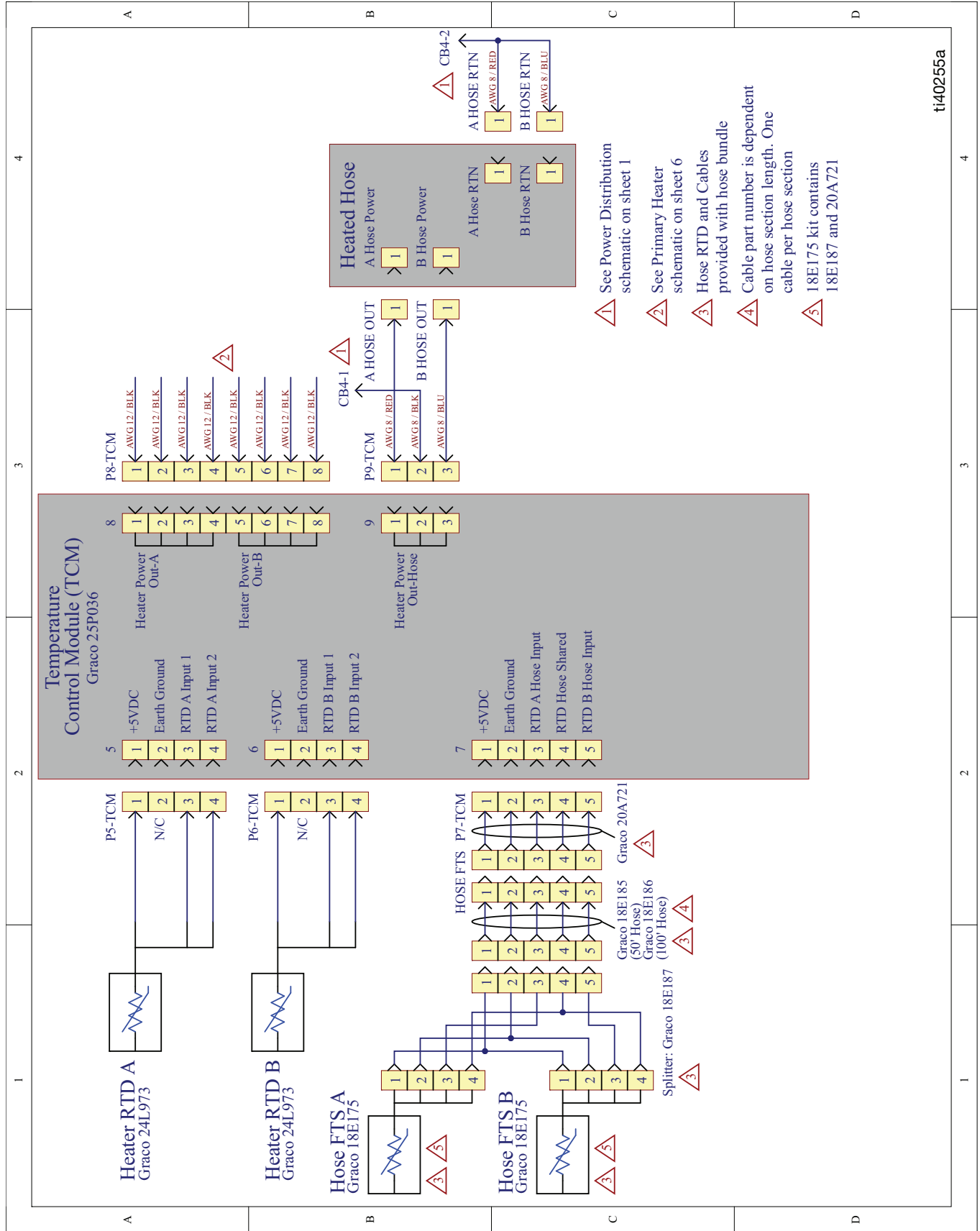

ti40255a



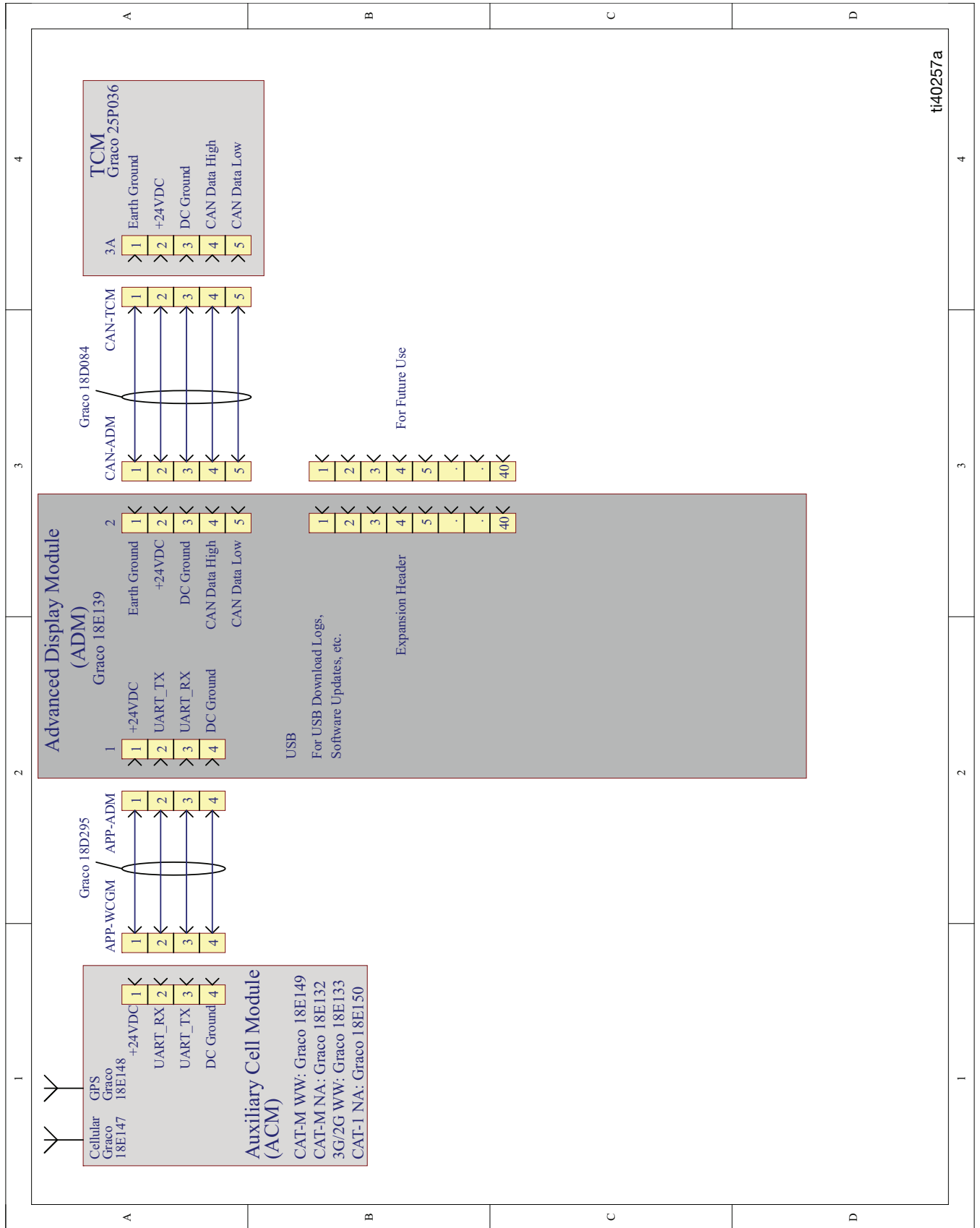

ti40257a

# Recycling and Disposal

## End of Product Life

At the end of a product's useful life, recycle it in a responsible manner.

## California Proposition 65

### CALIFORNIA RESIDENTS

 **WARNING:** Cancer and reproductive harm – [www.P65warnings.ca.gov](http://www.P65warnings.ca.gov).



# Technical Specifications

## Reactor E-20

Reactor 3 Proportioning Systems, E-20				
	U.S.		Metric	
Maximum Fluid Working Pressure	2000 psi		140 bar, 14 MPa	
Maximum Fluid Temperature	160 °F		71.1 °C	
Maximum Flow Rate	20 lb/min		9.07 kg/min.	
Maximum Heated Hose Length	220 ft		67 m	
Approximate Output Per Cycle (A+B)	0.0104 gal		39.4 cc	
Operating Ambient Temperature Range	20 °F to 120 °F		-7 °C to 49 °C	
Fluid Inlets	3/4 npt(f)			
Fluid Outlet – A	#8 (1/2 in.) JIC, with #5 (5/16 in.) JIC adapter			
Fluid Outlet – B	#10 (5/8 in.) JIC, with #6 (3/8 in.) JIC adapter			
Fluid Circulation Port Size	1/4 nps(m)			
Fluid Circulation Port Maximum Pressure	250 psi		17 bar, 1.7 MPa	
Wetted Parts	Aluminum, stainless steel, zinc-plated carbon steel, nickel-plated carbon steel, brass, tungsten carbide, chrome, chemically resistant o-rings, PTFE, acetal, ultra high molecule weight polyethylene			
Maximum Fluid Inlet Pressure	<b>Standard Models</b>	<b>Pro and Elite Models</b>	<b>Standard Models</b>	<b>Pro and Elite Models</b>
	400 psi	600 psi	27.6 bar, 2.76 MPa	41.3 bar, 4.14 MPa
<b>Line Voltage Requirement</b>				
200–240 VAC, 1–ph, 50/60 Hz				
200–240 VAC, 3–ph DELTA, 50/60 Hz				
350–415 VAC, 3–ph WYE, 50/60 Hz				
<b>Sound Pressure: Measured per ISO-9614-2</b>				
Measured from 3.1 ft (1 m) @ 3000 psi (21 MPa, 207 bar), 1 gpm (11.4 lpm)	90.1 dBA			
<b>Sound Power:</b>				
Measured from 3.1 ft (1 m) @ 3000 psi (21 MPa, 207 bar), 1 gpm (11.4 lpm)	97.15 dBA			
<b>Dimensions:</b>				
Width	24.9 in.		63 cm	
Depth	15.0 in.		38 cm	
Height	56.5 in.		144 cm	
<b>Weight:</b>				
Elite 10 kW	270 lb		122 kg	
<b>Notes:</b>				
All trademarks or registered trademarks are the property of their respective owners.				

# Reactor E-XP1

Reactor 3 Proportioning Systems, E-XP1				
	U.S.		Metric	
Maximum Fluid Working Pressure	3000 psi		207 bar, 20.7 MPa	
Maximum Fluid Temperature	180 °F		82.2 °C	
Maximum Flow Rate	2 gpm		7.6 lpm	
Maximum Heated Hose Length	220 ft		67 m	
Approximate Output Per Cycle (A+B)	0.0104 gal		39.4 cc	
Operating Ambient Temperature Range	20 °F to 120 °F		-7 °C to 49 °C	
Fluid Inlets	3/4 npt(f)			
Fluid Outlet – A	#8 (1/2 in.) JIC, with #5 (5/16 in.) JIC adapter			
Fluid Outlet – B	#10 (5/8 in.) JIC, with #6 (3/8 in.) JIC adapter			
Fluid Circulation Port Size	1/4 nps(m)			
Fluid Circulation Port Maximum Pressure	250 psi		17 bar, 1.7 MPa	
Wetted Parts	Aluminum, stainless steel, zinc-plated carbon steel, nickel-plated carbon steel, brass, tungsten carbide, chrome, chemically resistant o-rings, PTFE, acetal, ultra high molecule weight polyethylene			
Maximum Fluid Inlet Pressure	<b>Standard Models</b>	<b>Pro and Elite Models</b>	<b>Standard Models</b>	<b>Pro and Elite Models</b>
	400 psi	600 psi	27.6 bar, 2.76 MPa	41.3 bar, 4.14 MPa
<b>Line Voltage Requirement</b>				
200–240 VAC, 1–ph, 50/60 Hz				
200–240 VAC, 3–ph DELTA, 50/60 Hz				
350–415 VAC, 3–ph WYE, 50/60 Hz				
<b>Sound Pressure: Measured per ISO-9614-2</b>				
Measured from 3.1 ft (1 m) @ 3000 psi (21 MPa, 207 bar), 1 gpm (11.4 lpm)	85.1 dBA			
<b>Sound Power:</b>				
Measured from 3.1 ft (1 m) @ 3000 psi (21 MPa, 207 bar), 1 gpm (11.4 lpm)	92.15 dBA			
<b>Dimensions:</b>				
Width	24.9 in.		63 cm	
Depth	15 in.		38 cm	
Height	56.5 in.		144 cm	
<b>Weight:</b>				
Elite 10 kW	270 lb		122.5 kg	
<b>Notes:</b>				
All trademarks or registered trademarks are the property of their respective owners.				

# Reactor E-30

Reactor 3 Proportioning Systems, E-30				
	U.S.		Metric	
Maximum Fluid Working Pressure	2000 psi		140 bar, 14 MPa	
Maximum Fluid Temperature	160 °F		71.1 °C	
Maximum Flow Rate	30 lb/min		13.5 kg/min.	
Maximum Heated Hose Length	320 ft		97.5 m	
Approximate Output Per Cycle (A+B)	0.0273 gal		103.4 cc	
Operating Ambient Temperature Range	20 °F to 120 °F		-7 °C to 49 °C	
Fluid Inlets	3/4 npt(f)			
Fluid Outlet – A	#8 (1/2 in.) JIC, with #5 (5/16 in.) JIC adapter			
Fluid Outlet – B	#10 (5/8 in.) JIC, with #6 (3/8 in.) JIC adapter			
Fluid Circulation Port Size	1/4 nps(m)			
Fluid Circulation Port Maximum Pressure	250 psi		17 bar, 1.7 MPa	
Wetted Parts	Aluminum, stainless steel, zinc-plated carbon steel, nickel-plated carbon steel, brass, tungsten carbide, chrome, chemically resistant o-rings, PTFE, acetal, ultra high molecule weight polyethylene			
Maximum Fluid Inlet Pressure	<b>Standard Models</b>	<b>Pro and Elite Models</b>	<b>Standard Models</b>	<b>Pro and Elite Models</b>
	400 psi	600 psi	27.6 bar, 2.76 MPa	41.3 bar, 4.14 MPa
<b>Line Voltage Requirement</b>				
200–240 VAC, 1–ph, 50/60 Hz				
200–240 VAC, 3–ph DELTA, 50/60 Hz				
350-415 VAC, 3-ph WYE, 50/60 Hz				
<b>Sound Pressure: Measured per ISO-9614-2</b>				
Measured from 3.1 ft (1 m) @ 3000 psi (21 MPa, 207 bar), 1 gpm (11.4 lpm)	87.3 dBA			
<b>Sound Power:</b>				
Measured from 3.1 ft (1 m) @ 3000 psi (21 MPa, 207 bar), 1 gpm (11.4 lpm)	93.7 dBA			
<b>Dimensions:</b>				
Width	26.8 in.		68 cm	
Depth	15.0 in.		38 cm	
Height	56.5 in.		144 cm	
<b>Weight:</b>				
Elite 15 kW	335 lb		151.9 kg	
<b>Notes:</b>				
All trademarks or registered trademarks are the property of their respective owners.				

## Reactor E-XP2

Reactor 3 Proportioning Systems, E-XP2				
	U.S.		Metric	
Maximum Fluid Working Pressure	3500 psi		241 bar, 24.1 MPa	
Maximum Fluid Temperature	180 °F		82.2 °C	
Maximum Flow Rate	2.1 gpm		7.9 lpm	
Maximum Heated Hose Length	320 ft		97.5 m	
Approximate Output Per Cycle (A+B)	0.0203 gal		77.1 cc	
Operating Ambient Temperature Range	20 °F to 120 °F		-7 °C to 49 °C	
Fluid Inlets	3/4 npt(f)			
Fluid Outlet – A	#8 (1/2 in.) JIC, with #5 (5/16 in.) JIC adapter			
Fluid Outlet – B	#10 (5/8 in.) JIC, with #6 (3/8 in.) JIC adapter			
Fluid Circulation Port Size	1/4 nps(m)			
Fluid Circulation Port Maximum Pressure	250 psi		17 bar, 1.7 MPa	
Wetted Parts	Aluminum, stainless steel, zinc-plated carbon steel, nickel-plated carbon steel, brass, tungsten carbide, chrome, chemically resistant o-rings, PTFE, acetal, ultra high molecule weight polyethylene			
Maximum Fluid Inlet Pressure	<b>Standard Models</b>	<b>Pro and Elite Models</b>	<b>Standard Models</b>	<b>Pro and Elite Models</b>
	400 psi	600 psi	27.6 bar, 2.76 MPa	41.3 bar, 4.13 MPa
<b>Line Voltage Requirement</b>				
200–240 VAC, 1–ph, 50/60 Hz				
200–240 VAC, 3–ph DELTA, 50/60 Hz				
350–415 VAC, 3–ph WYE, 50/60 Hz				
<b>Sound Pressure: Measured per ISO-9614-2</b>				
Measured from 3.1 ft (1 m) @ 3000 psi (21 MPa, 207 bar), 1 gpm (11.4 lpm)	79.6 dBA			
<b>Sound Power:</b>				
Measured from 3.1 ft (1 m) @ 3000 psi (21 MPa, 207 bar), 1 gpm (11.4 lpm)	86.6 dBA			
<b>Dimensions:</b>				
Width	26.8 in.		68 cm	
Depth	15 in.		38 cm	
Height	56.5 in.		144 cm	
<b>Weight:</b>				
Elite kW	330 lb		149.7 kg	
<b>Notes:</b>				
All trademarks or registered trademarks are the property of their respective owners.				

# Graco Extended Warranty for Reactor® Components

Graco warrants all equipment referenced in this document which is manufactured by Graco and bearing its name to be free from defects in material and workmanship on the date of sale to the original purchaser for use. With the exception of any special, extended, or limited warranty published by Graco, Graco will, for a period of twelve months from the date of sale, repair or replace any part of the equipment determined by Graco to be defective. This warranty applies only when the equipment is installed, operated and maintained in accordance with Graco's written recommendations.

Graco Part Number	Description	Warranty Period
25R357	Electric Motor, 1.75 HP	36 Months or 3 Million Cycles
25R359	Electric Motor, 2.5 HP	36 Months or 3 Million Cycles
18B011	Motor Control Module	36 Months or 3 Million Cycles
25P036	Temperature Control Module	36 Months or 3 Million Cycles
18E139	Advanced Display Module	36 Months or 3 Million Cycles
All other Reactor 3 parts		12 Months

This warranty does not cover, and Graco shall not be liable for general wear and tear, or any malfunction, damage or wear caused by faulty installation, misapplication, abrasion, corrosion, inadequate or improper maintenance, negligence, accident, tampering, or substitution of non-Graco component parts. Nor shall Graco be liable for malfunction, damage or wear caused by the incompatibility of Graco equipment with structures, accessories, equipment or materials not supplied by Graco, or the improper design, manufacture, installation, operation or maintenance of structures, accessories, equipment or materials not supplied by Graco.

This warranty is conditioned upon the prepaid return of the equipment claimed to be defective to an authorized Graco distributor for verification of the claimed defect. If the claimed defect is verified, Graco will repair or replace free of charge any defective parts. The equipment will be returned to the original purchaser transportation prepaid. If inspection of the equipment does not disclose any defect in material or workmanship, repairs will be made at a reasonable charge, which charges may include the costs of parts, labor, and transportation.

**THIS WARRANTY IS EXCLUSIVE, AND IS IN LIEU OF ANY OTHER WARRANTIES, EXPRESS OR IMPLIED, INCLUDING BUT NOT LIMITED TO WARRANTY OF MERCHANTABILITY OR WARRANTY OF FITNESS FOR A PARTICULAR PURPOSE.**

Graco's sole obligation and buyer's sole remedy for any breach of warranty shall be as set forth above. The buyer agrees that no other remedy (including, but not limited to, incidental or consequential damages for lost profits, lost sales, injury to person or property, or any other incidental or consequential loss) shall be available. Any action for breach of warranty hereunder must be brought within the latter of two (2) years of the date of sale, or one (1) year the warranty period expires.

**GRACO MAKES NO WARRANTY, AND DISCLAIMS ALL IMPLIED WARRANTIES OF MERCHANTABILITY AND FITNESS FOR A PARTICULAR PURPOSE, IN CONNECTION WITH ACCESSORIES, EQUIPMENT, MATERIALS OR COMPONENTS SOLD BUT NOT MANUFACTURED BY GRACO.** These items sold, but not manufactured by Graco (such as electric motors, switches, hose, etc.), are subject to the warranty, if any, of their manufacturer. Graco will provide purchaser with reasonable assistance in making any claim for breach of these warranties.

In no event will Graco be liable for indirect, incidental, special or consequential damages resulting from Graco supplying equipment hereunder, or the furnishing, performance, or use of any products or other goods sold hereto, whether due to a breach of contract, breach of warranty, the negligence of Graco, or otherwise.

#### FOR GRACO CANADA CUSTOMERS

The Parties acknowledge that they have required that the present document, as well as all documents, notices and legal proceedings entered into, given or instituted pursuant hereto or relating directly or indirectly hereto, be drawn up in English. Les parties reconnaissent avoir convenu que la rédaction du présente document sera en Anglais, ainsi que tous documents, avis et procédures judiciaires exécutés, donnés ou intentés, à la suite de ou en rapport, directement ou indirectement, avec les procédures concernées.

## Graco Information

For the latest information about Graco products, visit [www.graco.com](http://www.graco.com).

For patent information, see [www.graco.com/patents](http://www.graco.com/patents).

**TO PLACE AN ORDER**, contact your Graco distributor or call to identify the nearest distributor.

**Phone:** 612-623-6921 or **Toll Free:** 1-800-328-0211, **Fax:** 612-378-3505

*All written and visual data contained in this document reflects the latest product information available at the time of publication.  
Graco reserves the right to make changes at any time without notice.*

Original instructions. This manual contains English. MM 3A8501

**Graco Headquarters:** Minneapolis

**International Offices:** Belgium, China, Japan, Korea

**GRACO INC. AND SUBSIDIARIES • P.O. BOX 1441 • MINNEAPOLIS MN 55440-1441 • USA**  
**Copyright 2021, Graco Inc. All Graco manufacturing locations are registered to ISO 9001.**

[www.graco.com](http://www.graco.com)  
Revision F, September 2022